

Fuse Box

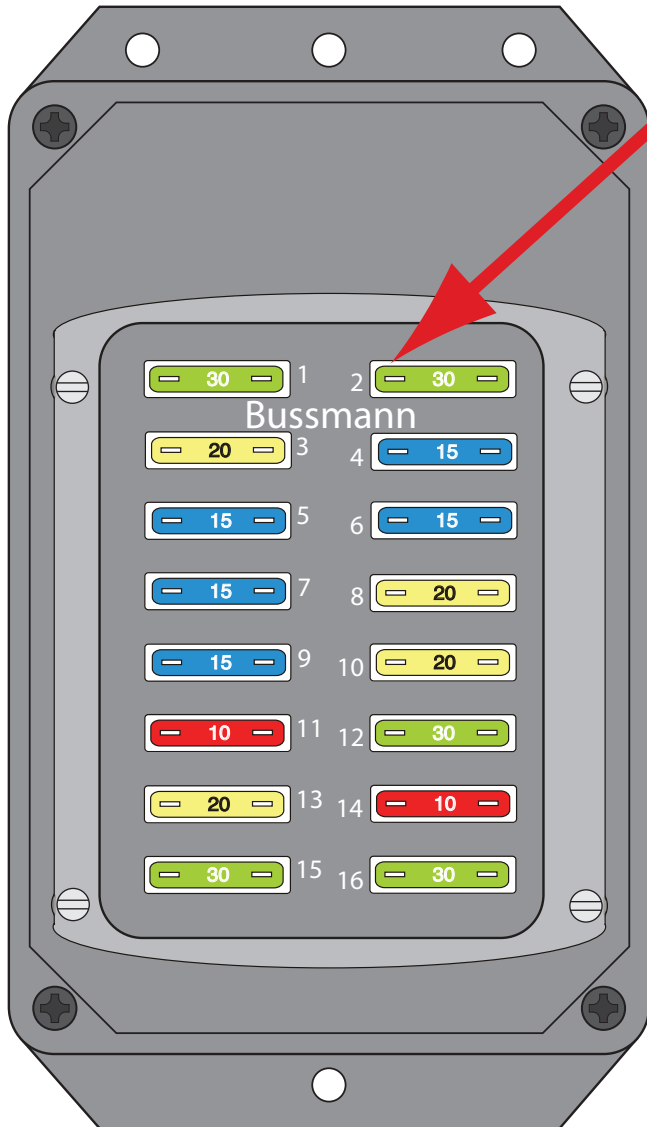

**NOTE:**

If your fuse box looks like this, these **ARE** the correct instructions for your application. If the word “Bussmann” does not appear on the fuse box, you have a different version of this kit and these **ARE NOT** the correct instructions.

**KIT BOX CONTENTS:**

<u>Bag</u>	<u>Part Number</u>	<u>Description</u>	<u>Quantity</u>
	500042	Floor Dimmer Switch	1
	500332	Headlight Switch	1
	500684	Ignition Switch	1
	500919	Practice Terminal Crimping Set	1
	510145	Fuse, Relay, and Flasher kit	1
G	510613	Dash Harness kit	1
H	510614	Instrument Cluster wiring kit	1
J	510615	Engine Wiring Kit	1
L	510616	Front Light Wiring kit	1
M	510619	Rear Body Wiring kit	1
N	510620	Headlight Extension Wiring kit	1
Z	510476	Alternator and Main Power kit	1
	92971437	Firewall Template	1



**American  
Autowire**

www.americanautowire.com 856-933-0801

Classic Update Kit  
1963-67 Corvette

**510612**

92974033 Rev. 0.0 03/22/2024

Align this template along the factory opening. You will need to remove a very small amount of material from the left hand and bottom edges of the stock bulkhead opening. This can be done with a good, sharp file, or a dremel tool.

Drill new mounting hole with a 0.125 bit 

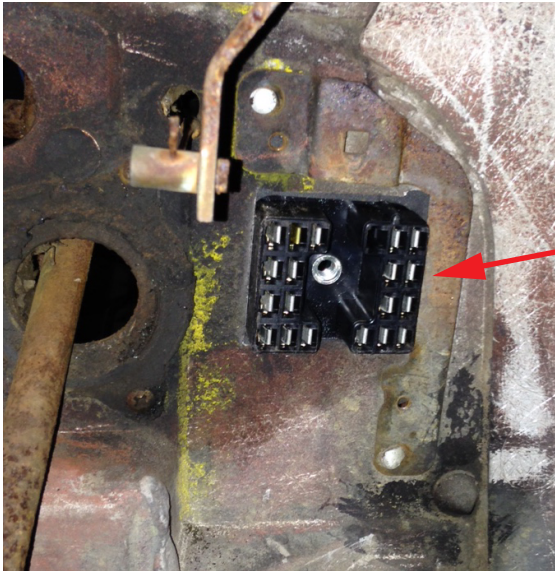

bulkhead connector, viewed from engine compartment

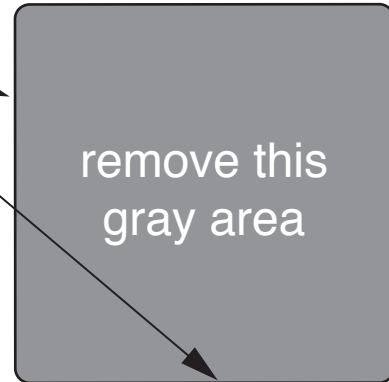

Viewed from engine compartment

Drill new mounting hole with a 0.125 bit 

## Firewall modification template for the 1963 - 1967 Corvette Classic Update Kit

This Classic Update Series kit uses a later style GM bulkhead assembly which has a different mounting footprint than the original bulkhead connector for your car. Therefore, it will be necessary to modify your firewall to accept this later design bulkhead. This enclosed template must be used for this purpose.

The gray area should be cut out with a razor knife to define the area of material that needs to be removed from the existing bulkhead area. We suggest that this template be glued to a stiff piece of cardboard or thin piece of plastic, or be applied directly to the cleaned firewall on the **engine compartment** side of the car, then proceed as follows:

1. Position the template against the firewall aligning the top and right hand edges with the top and right hand edges of the existing bulkhead opening in the firewall.
2. Trace the new bulkhead opening area onto the existing firewall and cut out the area that needs to be removed. It may be necessary the do some fine tuning on the hole size for an exact fit.
3. Drill two new 0.125 holes as shown above. Using the 2 new bulkhead mounting washers and screws provided in the dash loose piece kit, attach the new bulkhead into the firewall taking note to keep the indexing nub on the bulkhead connector up and to the left (from the inside of the car).

**PRINT ON ADHESIVE LABEL SHEET**

**92971437**

Firewall Template instructions  
Rev 0.0 11/29/2016

PRINTING INSTRUCTIONS: **DO NOT FIT TO PAGE OR SCALE**



**WARNING:**

Validate the kit contents with the component list included on this page, before proceeding. This kit is intended to be used in a modified vehicle. Please read this page thoroughly and be sure that you understand everything explained on it prior to opening any of the enclosed packages, or before attempting to install any of the components. Once this kit has been opened or a component installed, the kit is not returnable.

1. This new upgraded AAW wiring system should typically be used in a **MODIFIED** application only.
2. This kit includes the wiring to support the use of a factory heater only system and/or aftermarket heater and A/C systems. This kit does not include the wiring for the factory original A/C system.
3. This kit supports the use of a high current self-exciting 1-wire, "SI" series, or other style internally regulated alternator. An adapter may be necessary in some applications. The use of stock, low amperage alternators is seriously discouraged as they cannot handle the higher current requirements of most updated ignition systems, electric fans, aftermarket A/C systems, stereo systems, air ride suspensions, and other power hungry accessories that will ultimately create performance issues within the system.
4. AAW **DOES NOT** support the use of an ammeter. All AAW kits are engineered to supply the optimum charge to the battery. To achieve this performance, we route our 6ga. charge wire directly from the alternator output charge terminal to the starter battery terminal. Due to the path of the charge being altered from the stock configuration, the gauge can no longer see a charge vs. a discharge, so it may not work properly. Most stock alternator current outputs were rated at a maximum of about 37-60 amps. Modified cars being built today typically utilize a 100 amp or higher output alternator. With these higher current units, ammeters, generally speaking, become a safety hazard. Ammeters are usually wired in parallel to the charging circuit, are typically unfused, and can short very easily causing a fire. This wiring system has been designed to work with a voltmeter.
5. This kit **IS NOT** set up with a resistance wire for a standard, points type ignition system. It is wired with a full 12-volt primary ignition feed that is hot in the crank and run positions. Our system will support HEI, MSD, other electronic ignition systems, as well as most all computerized Fuel Injection systems. If you wish to run a points type system, there are illustrations on the engine connection pages to do so. Primary ignition voltage in the cranking position is handled via a full 12 volt bypass wire that is routed from the starter "R" terminals to the positive side on the coil. Extra parts (ballast resistor) that are not included in this kit will be required to complete that type of operation.

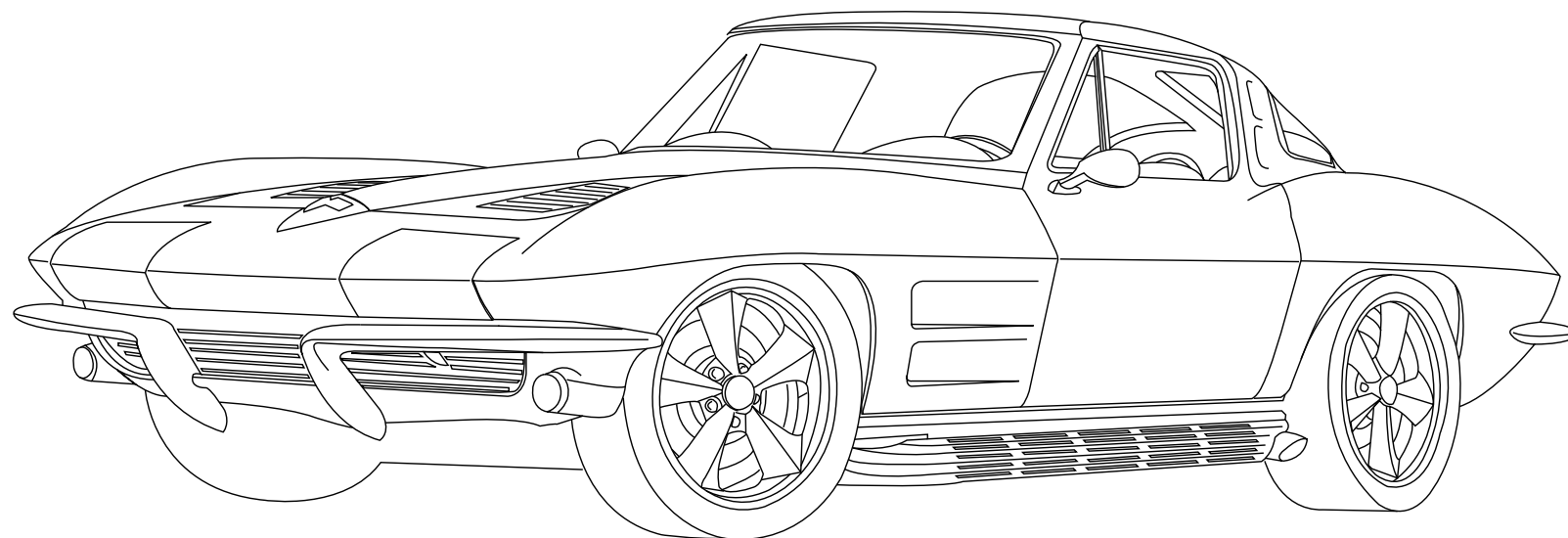

**510612 - Classic Update Series Kit  
1963-67 Chevrolet Corvette**

This kit contains the following components:

Bag	Part Number	Description	Quantity
	500042	Floor Dimmer Switch	1
	500332	Headlight Switch	1
	500684	Ignition Switch	1
	500919	Practice Terminal Crimping Set	1
	510145	Fuse, Relay, and Flasher kit	1
G	510613	Dash Harness kit	1
H	510614	Instrument Cluster wiring kit	1
J	510615	Engine Wiring Kit	1
L	510616	Front Light Wiring kit	1
M	510619	Rear Body Wiring kit	1
N	510620	Headlight Extension Wiring kit	1
Z	510476	Alternator and Main Power kit	1
	92971437	Firewall Template	1

Validate the kit contents with this component list. If there are any discrepancies with incorrect or missing parts, stop your installation and notify the supplier you purchased the kit from before proceeding.



www.americanautowire.com 856-933-0801

**1963-67 Corvette**  
*Classic Update Series*  
**510612**

© COPYRIGHT 2004 American Autowire / Factory-Fit  
Used with express permission of  
American Autowire / Factory-Fit

92971411 Rev 7.0 1/7/2019



# START HERE !

## PLEASE READ THIS BEFORE STARTING INSTALLATION !

This wiring kit is designed for ease of installation. Please read the guidelines below, BEFORE STARTING your installation, to guarantee a successful job. Use an appropriate crimping tool, which folds the wings of the open barrel terminals down into the wire, as shown on this page. If you use our crimping tools and correctly crimp the included terminals, soldering is not necessary. If you are unsure about a particular crimp, soldering is recommended. Our factory crimped terminations are installed by GM approved five ton presses, and soldering these terminations is not necessary.



AAW offers a great terminal crimping video entitled "Proper Crimping Video". It can be viewed by visiting YouTube.

Type the following address into your web browser, to go directly to the video:  
[www.youtube.com/watch?v=JAgEDoVI-co](http://www.youtube.com/watch?v=JAgEDoVI-co)

Youtube Channel:  
[www.youtube.com/user/WiringHarness](http://www.youtube.com/user/WiringHarness)



### Factory Assembly Manuals

- 1963 p/n 36337
- 1964 p/n 36338
- 1965 p/n 36339
- 1966 p/n 36340
- 1967 p/n 36341

The terminals that we supply in our kits, utilize what is known as an F crimp. The F crimp, in a cross section, will look like the illustration below, when done correctly.

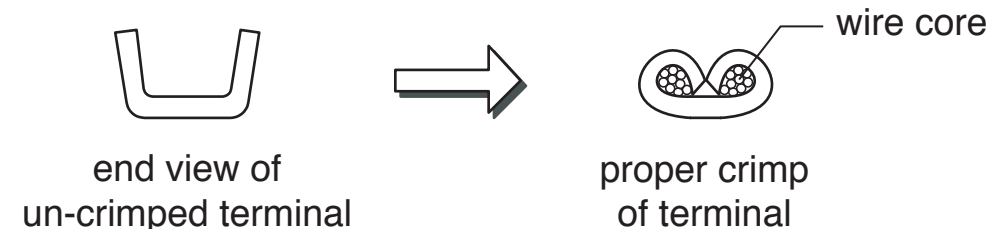

We carry the following crimping hand tools, to help with your terminal crimping. These hand tools are available, for purchase or rental.

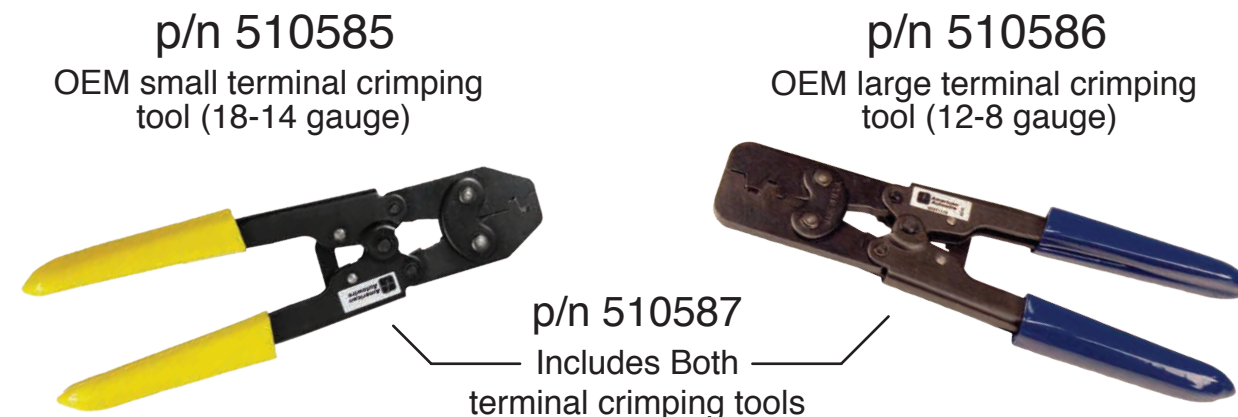

We carry many accessories for your 1963-67 Corvette.



Full vehicle grounding kit  
p/n 500717



Optional Third Tail Light Kit  
p/n 510679



64-65 Corvette Rear Mounted Blower Kit  
p/n 510681

### STEP 1: DISCONNECT YOUR BATTERY:

Disconnect the battery, before installing the wiring kit, to prevent any accidental shorting caused by loose bare wire ends.



If you have any questions concerning this or any of our products, please feel free to call us at 1-856-933-0801.

## STEP 2: START INSTALLING KIT:

This kit is broken down into individual sections, that are identified by a letter printed on the enclosed sheets, visible through each bag. The order of installation and the pages with their installation instructions, are shown below:

## Table of Contents:

### Bags: Pages: Sections:

- G 4 - 9 Dash Harness - This is the main harness in the kit and contains:**
- Starter solenoid connections.
  - Wiper motor connections
  - Brake light switch connection.
  - Neutral safety switch connection.
  - Door jamb switches.
  - Wiper module and switch connections
  - Defrost module and switch connections.
  - Headlight and fog light connections.
- H 10 - 14 Gauge Cluster Harness - This Harness contains:**
- Gauge connections for aftermarket and factory gauges.
- M 15 - 19 Rear Body Harness - This Harness contains:**
- Tail light, turn signal, reverse light, and running light connections.
  - Hatch connections; third brake light, license plate lights, and rear defroster connections.
  - Fuel pump connections.
- L 20 - 22 Front Light Harness - This Harness contains:**
- Headlight, turn signal, running light connections.
  - Fog lamp wiring.
  - Windshield washer connection.
  - Electric fan relay trigger.
  - Brake fluid level wiring.
- J 23 - 25 Engine Harness - This Harness contains:**
- Temperature, oil pressure, tachometer wiring.
  - Ignition system / ECU power.
  - A/C compressor connections.
  - Alternator connections.



## PLEASE READ THIS HELPFUL INSTALLATION TIP, BEFORE GOING ANY FURTHER!

Prior to installing the Dash/Main harness in your dashboard, plug all of the fuses (see detailed picture below), Horn Relay, Hazard Flasher and Turn Flasher (see detailed picture below), into this harness.

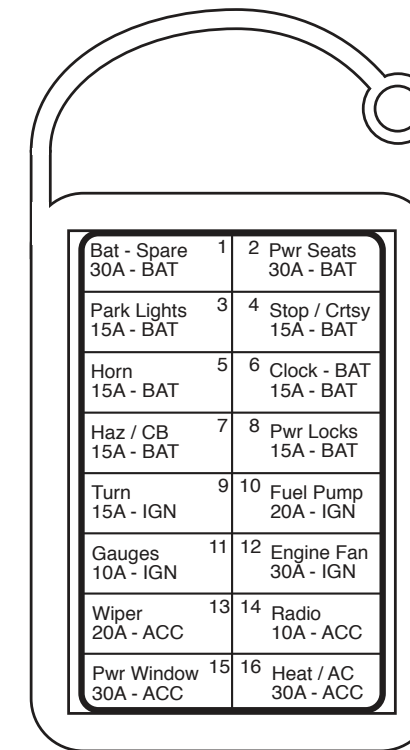

Fuse label on inside of Fuse Box Cover

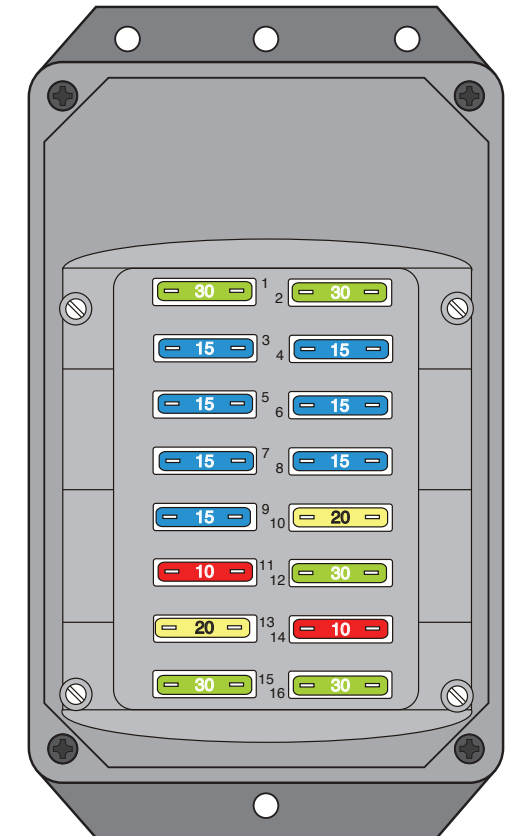



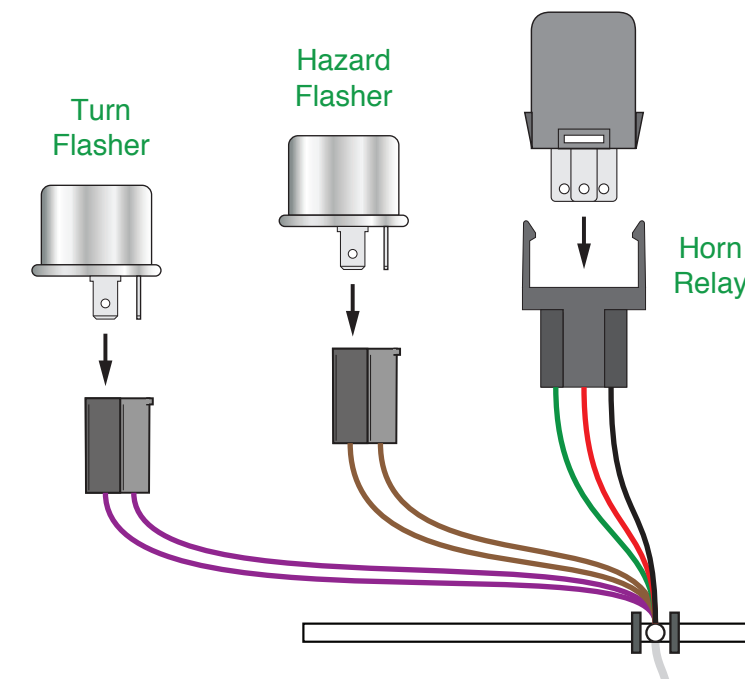





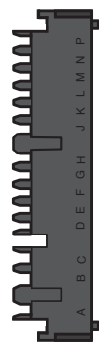
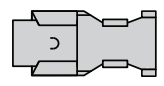
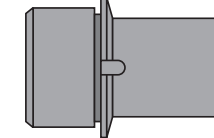

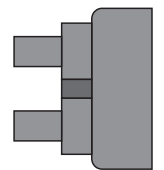
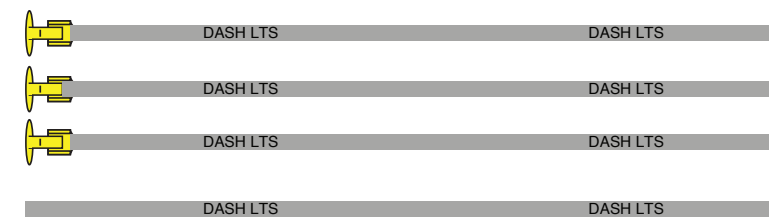
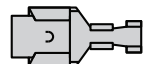
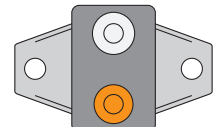

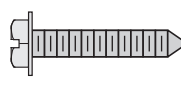



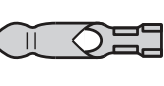

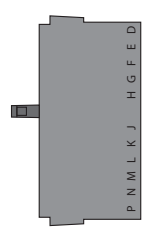

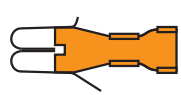

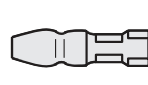
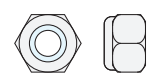
Fuse installation orientation.

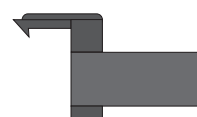

## Dash/Main harness installation instructions:

Shown below, are the supplied misc. terminals, plastic connector bodies, hardware, jumpers and extensions that will be used to complete your Dash/Main harness connections. They are itemized and referred to on this page, just as they are on the following pages of this Dash/Main instruction set.

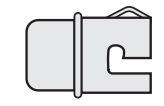
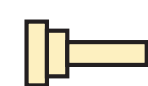
<p><b>A</b>  (Pack-con 14-way male conn, 1 pc.)</p>	<p><b>L</b>  (56 series double female terminal, 9 pcs.)</p>	<p><b>CC</b>  (grommet, 2 way, 1 pc.)</p>
<p><b>B</b>  (male flat Pack-con terminal, 11 pcs.)</p>	<p><b>M</b>  (cover, circuit breaker, 1 pc.)</p>	<p><b>DD</b>  (Dash Light Extensions - reference, 4 pcs.)</p>
<p><b>C</b>  (56 series single female terminal, 8 pcs.)</p>	<p><b>N</b>  (circuit breaker, 1 pc.)</p>	<p><b>EE</b>  (Power Antenna Jumper - reference, 1 pc.)</p>
<p><b>D</b>  (screw, 1", fuse box, 5 pcs.)</p>	<p><b>P</b>  (sleeve, long, 2 pcs.)</p>	<p><b>FF</b>  (Dash Light Candelabra Jumper - reference, 1 pc.)</p>
<p><b>E</b>  (washer, 1/4", 2 pcs.)</p>	<p><b>Q</b>  (single male bullet terminal, 4 pcs.)</p>	<p><b>GG</b>  (Headlight Door Jumper - reference, 1 pc.)</p>
<p><b>F</b>  (Pack-con 11-way female conn, 1 pc.)</p>	<p><b>R</b>  (ring terminal, 4 pcs.)</p>	<p><b>HH</b>  (1963 only Parking Brake Extension - reference, 1 pc.)</p>
<p><b>G</b>  (female Pack-con terminal, 11 pcs.)</p>	<p><b>T</b>  (sleeve, short, 4 pcs.)</p>	<p><b>JJ</b>  (Glove box Light Extension - reference, 1 pc.)</p>
<p><b>H</b>  (single male bullet terminal, 6 pcs.)</p>	<p><b>U</b>  (10-32 nut, 2 pcs.)</p>	<p><b>KK</b>  (Turn Signal Switch Jumper, 1963 only - reference, 1 pc.)</p>
<p><b>J</b>  (56 series 2-way female conn, 1 pc.)</p>	<p><b>V</b>  (washer, 10-32, 2 pcs.)</p>	<p><b>LL</b>  (spring, light socket, 1 pc.)</p>
<p><b>K</b>  (56 series single female conn, 4 pcs.)</p>	<p><b>W</b>  (light socket, 2 pcs.)</p>	
	<p><b>Y</b>  (56 series single female conn, 1 pc.)</p>	
	<p><b>AA</b>  (smaller metal light socket, 1964 and up only, 1 pc.)</p>	
	<p><b>BB</b>  (light socket sleeve, 1 pc.)</p>	

# Dash/Main harness installation instructions:



www.americanautowire.com 856-933-0801

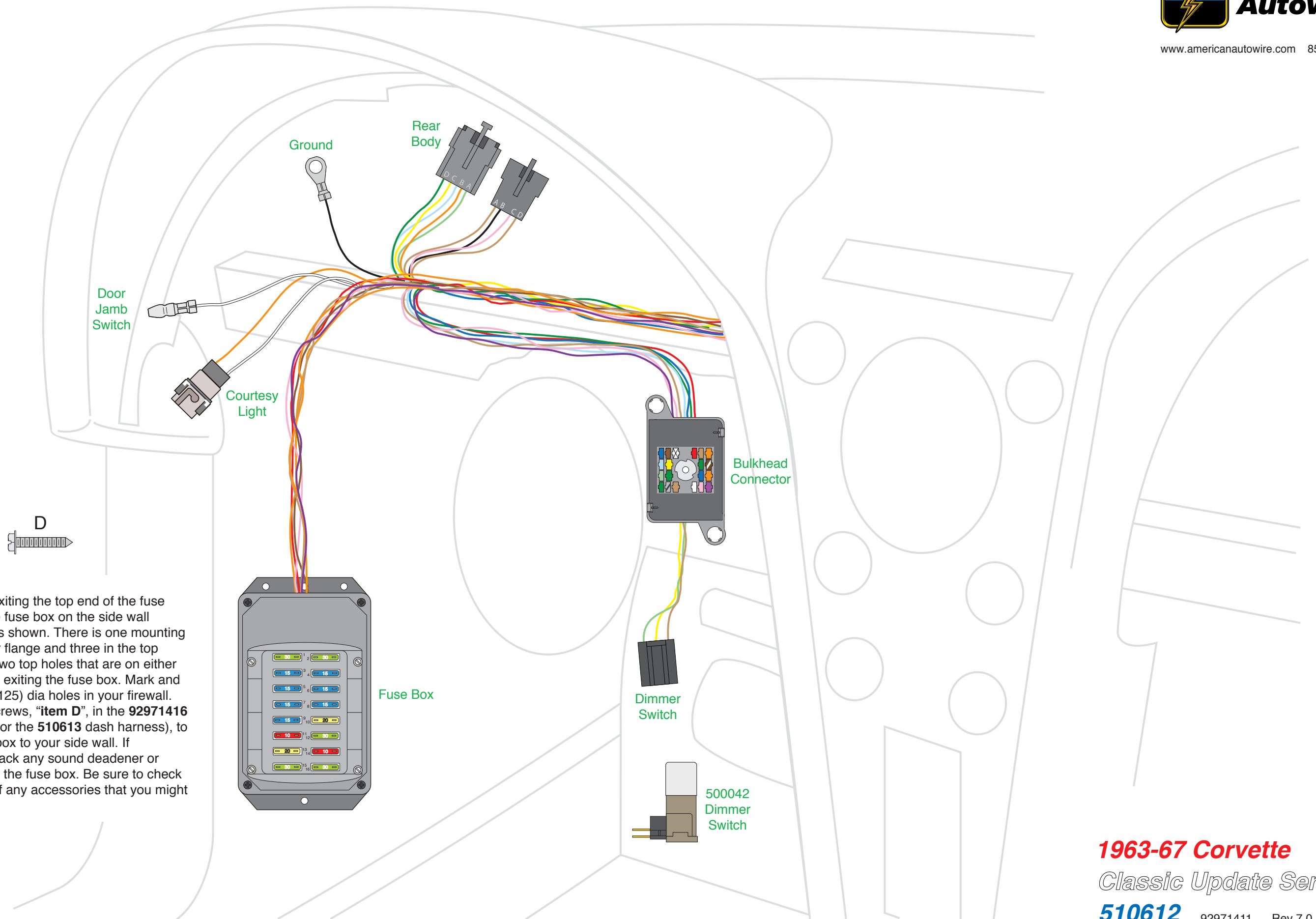

**NOTE:** With the wires exiting the top end of the fuse box, position the fuse box on the side wall approximately as shown. There is one mounting hole in the lower flange and three in the top flange; use the two top holes that are on either side of the wires exiting the fuse box. Mark and drill three 1/8" (.125) dia holes in your firewall. Use the three screws, "item D", in the 92971416 loose piece kit (for the 510613 dash harness), to attach the fuse box to your side wall. If necessary, cut back any sound deadener or carpet, to mount the fuse box. Be sure to check for clearances of any accessories that you might be adding.

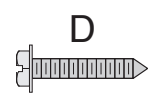



# Dash/Main harness installation instructions:



www.americanautowire.com 856-933-0801

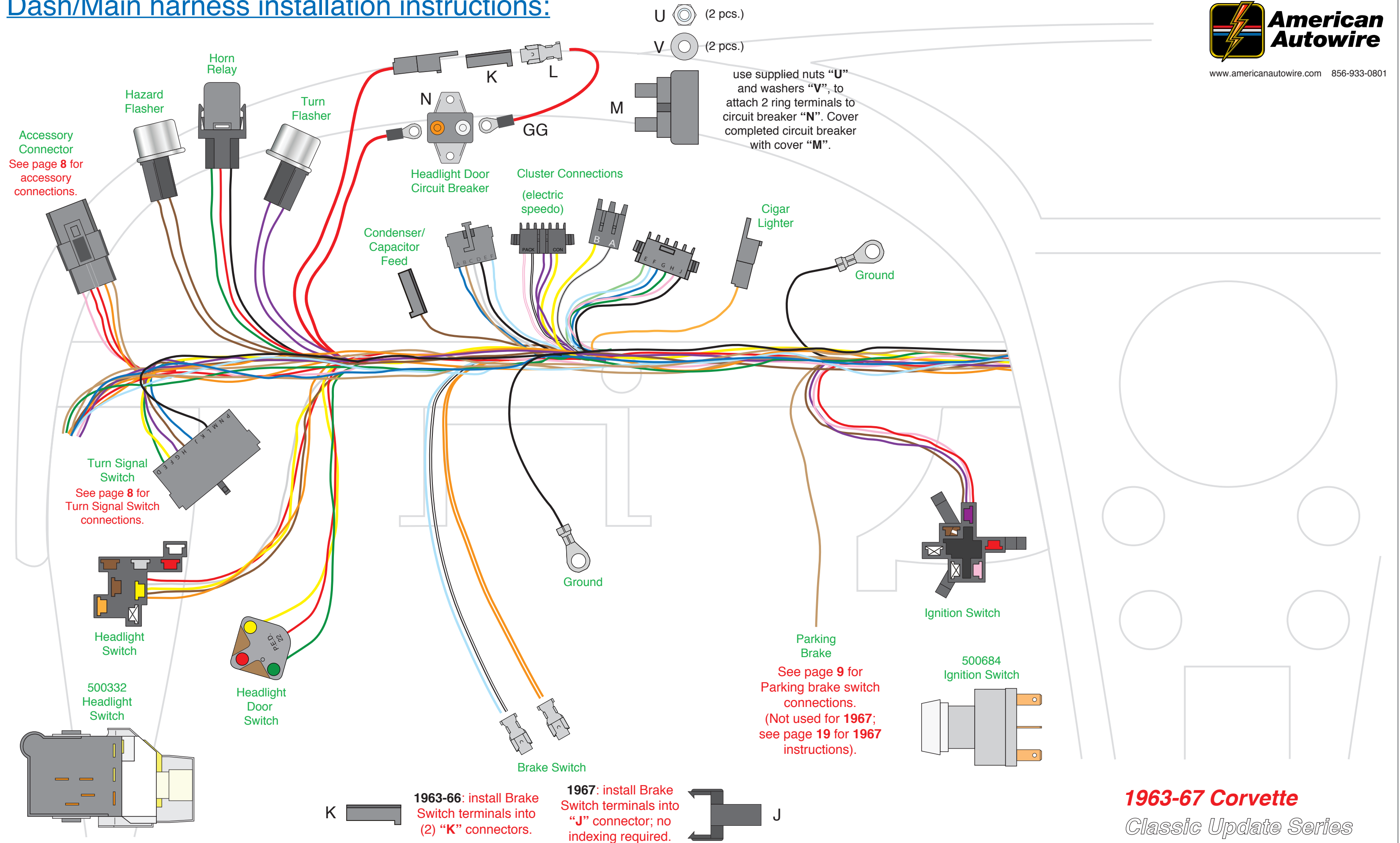



# Dash/Main harness installation instructions:



www.americanautowire.com 856-933-0801

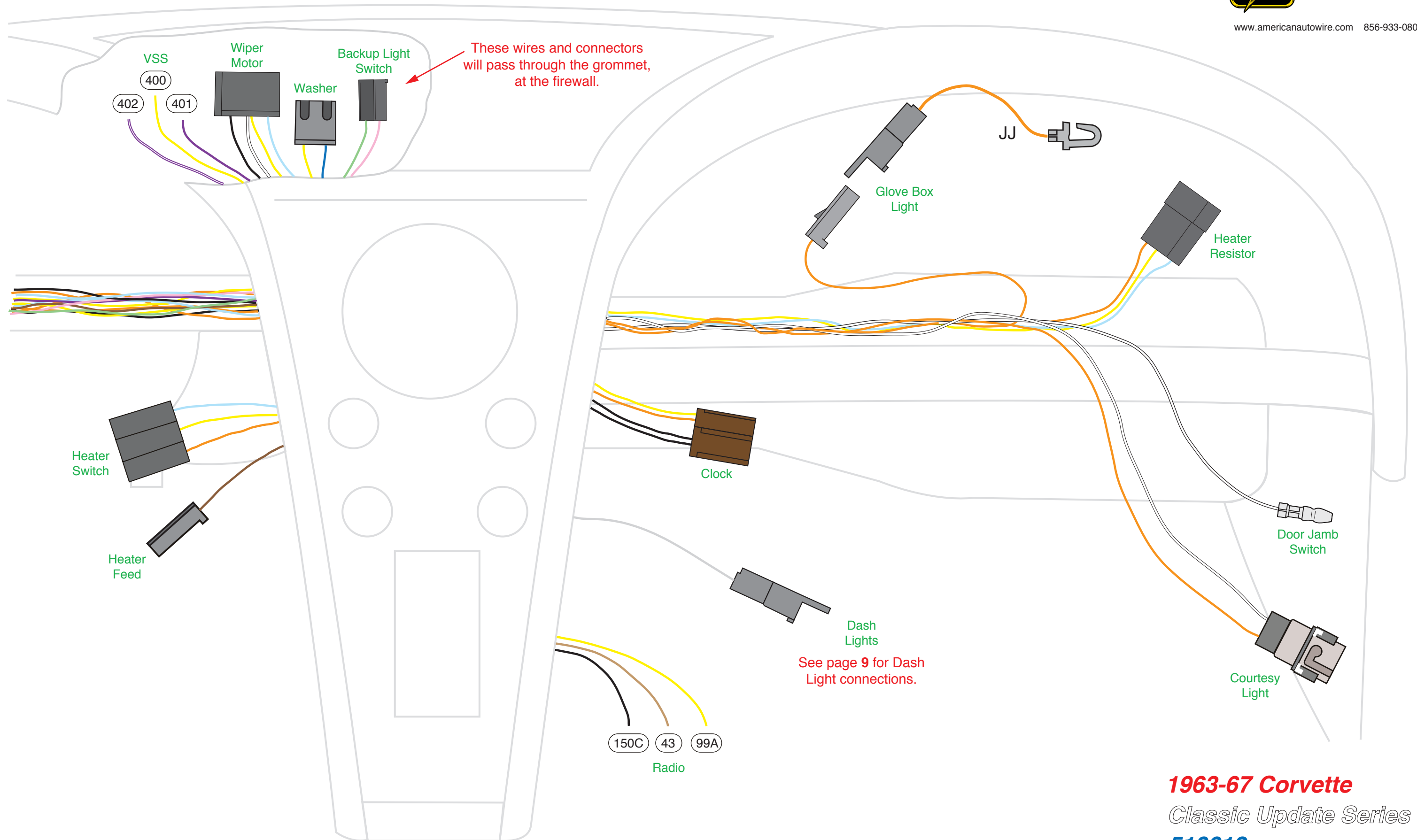

# Dash/Main harness installation instructions:

## “Table B”

AAW Turn Signal Switch wires to stock **1963-67**  
Chevrolet Corvette Turn Signal Switch

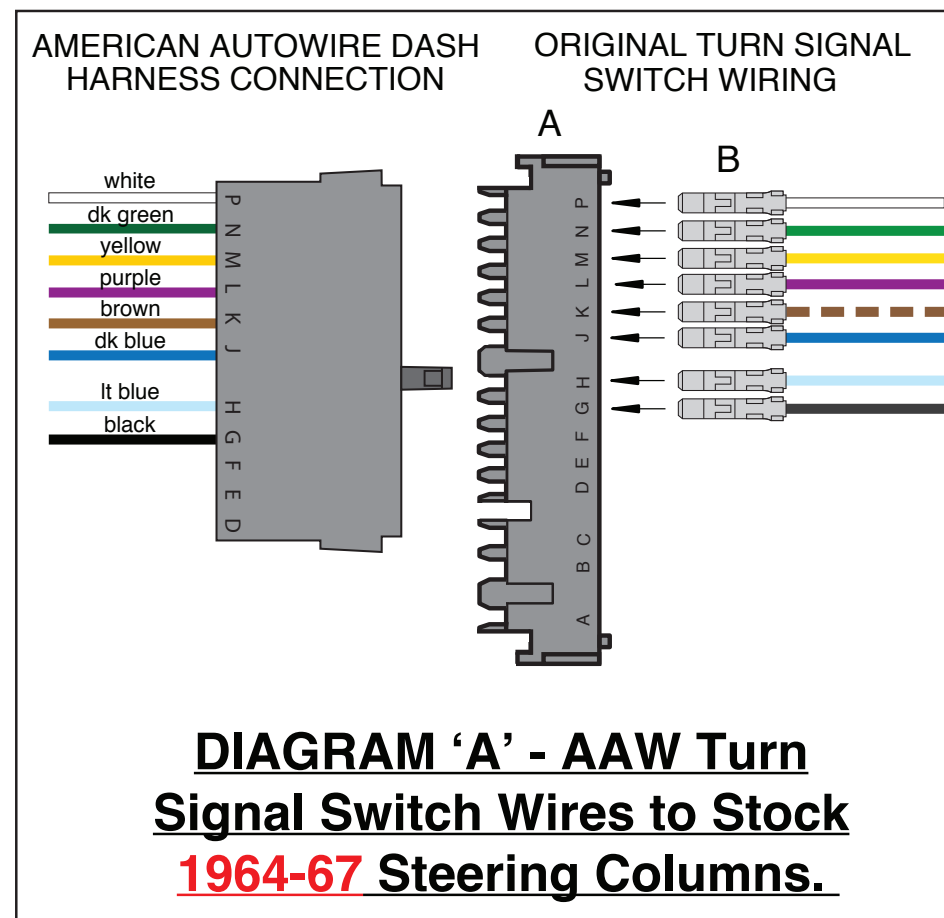
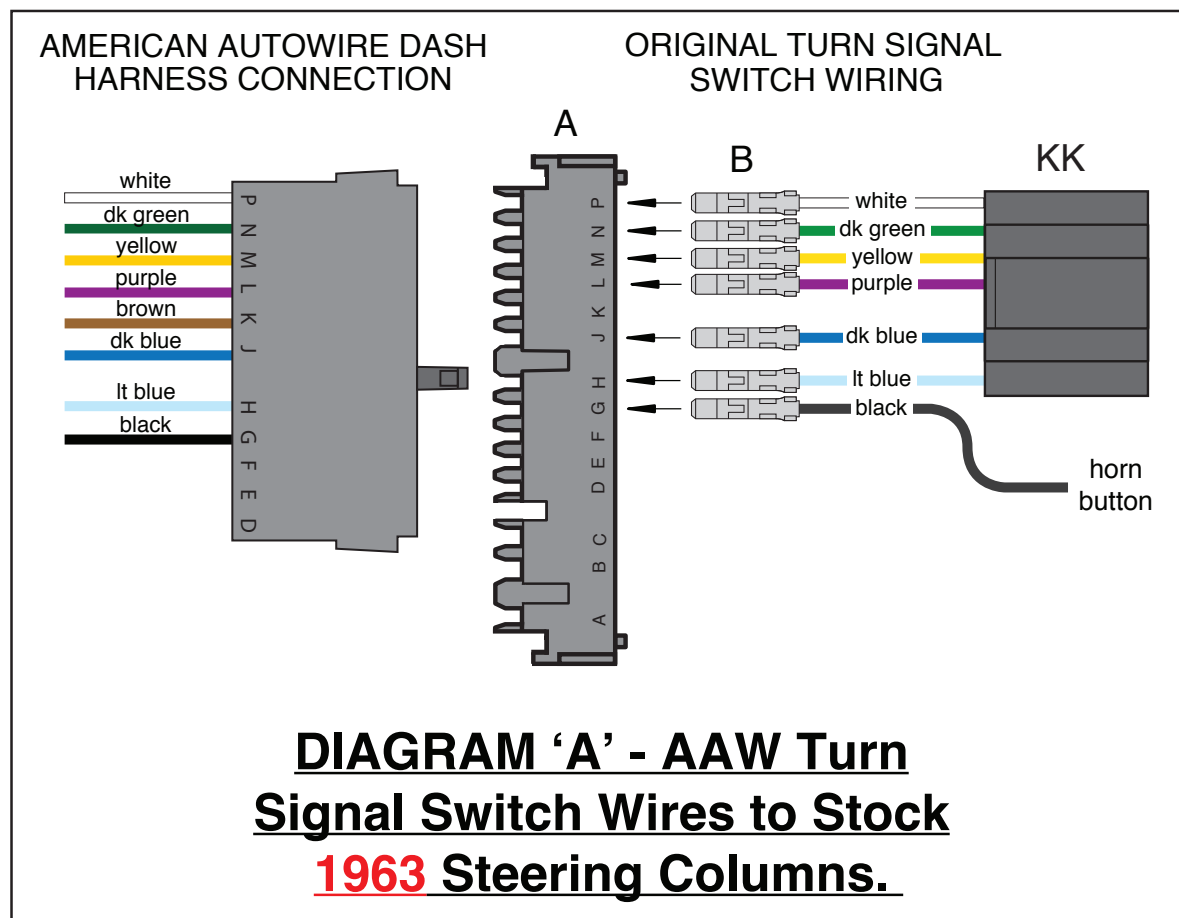

AAW Wire Color	AAW Wire Printing	Connector Cavity AAW
White	Brake SW	P
Dark Green	Right Rear Turn	N
Yellow	Left Rear Turn	M
Purple	Turn Switch Feed	L
Brown	Turn SW – Hazard	K (aftermarket only)
Dark Blue	Right Front Turn	J
Light Blue	Left Front Turn	H
Black	Horn Relay Ground	G
None	None	F
None	None	E
None	None	D

**Note: 1963 only:** Remove the original Turn Signal Switch Connector and replace it with the AAW 14-way connector “A” and Turn Signal Switch Jumper “KK”. Crimp on terminal “B” to each of the Jumper “KK” wires and plug them into connector “A” (see Parts Kit 92971416).

**1964-67 only:** Remove the original Turn Signal Switch Connector and replace it with the AAW 14-way connector “A”. Crimp on terminal “B” to each of the original Turn Signal Switch wires and plug them into connector “A” (see Parts Kit 92971416).

Use “Table B” above to align the wires. Also, for all of the vehicles, the Steering Column Horn Button switches ground for the Horn Relay, which then switches power to the Horns, similar to the AAW design.

## Accessory Connector

Use the provided 6-way empty connector, which is attached to the 6-way Accessory connector on the Dash Harness, and terminals “C” and “L” to add power wires (not provided) for the following optional systems:

Wire Color	Printing	Fuse #	Fuse Block Cover	Fuse rating	Description
Red	CB-RADIO	7	Haz / CB	15A	Fused 12 volt BATTERY feed for cruise control (may also be used to feed power to another battery circuit).
Tan	FUEL PUMP	10	Fuel Pump	20A	Fused 12 volt IGNITION feed for fuel pump (may also be used to feed power to another ignition circuit).
Orange	POWER SEATS	2	Pwr Seats	30A	Fused 12 volt BATTERY feed for power seats (may also be used to feed power to another battery circuit).
Red	POWER LOCKS	8	Pwr Locks	15A	Fused 12 volt BATTERY feed for power door locks (may also be used to feed power to another battery circuit).
Pink	POWER WINDOWS	15	Pwr Window	30A	Fused 12 volt ACCESSORY feed for power windows (may also be used to feed power to another accessory circuit).
Orange	12V BATTERY FUSED	1	Bat-Spare	30A	Fused 12 volt BATTERY feed (may also be used to feed power to a battery circuit).



www.americanautowire.com 856-933-0801

**1963-67 Corvette**  
Classic Update Series  
**510612** 92971411 Rev 7.0 1/7/2019

# Dash/Main harness installation instructions:

## Parking Brake switch wiring:

For 1963:

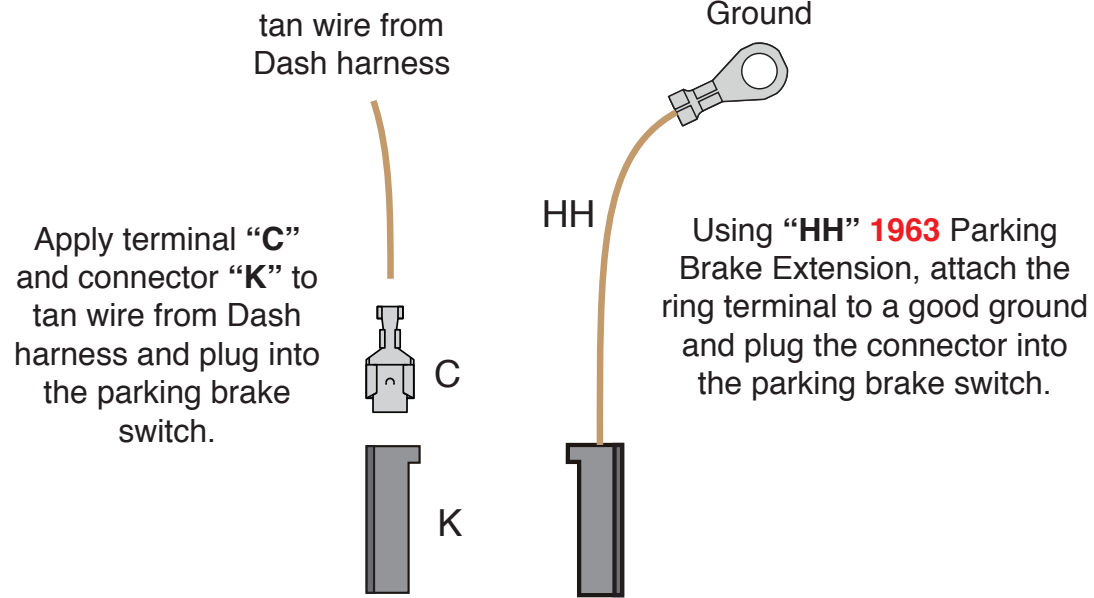

For 1964-66:

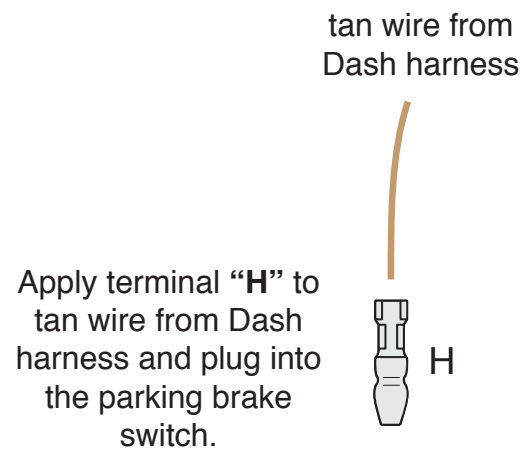

## Power Antenna wiring:

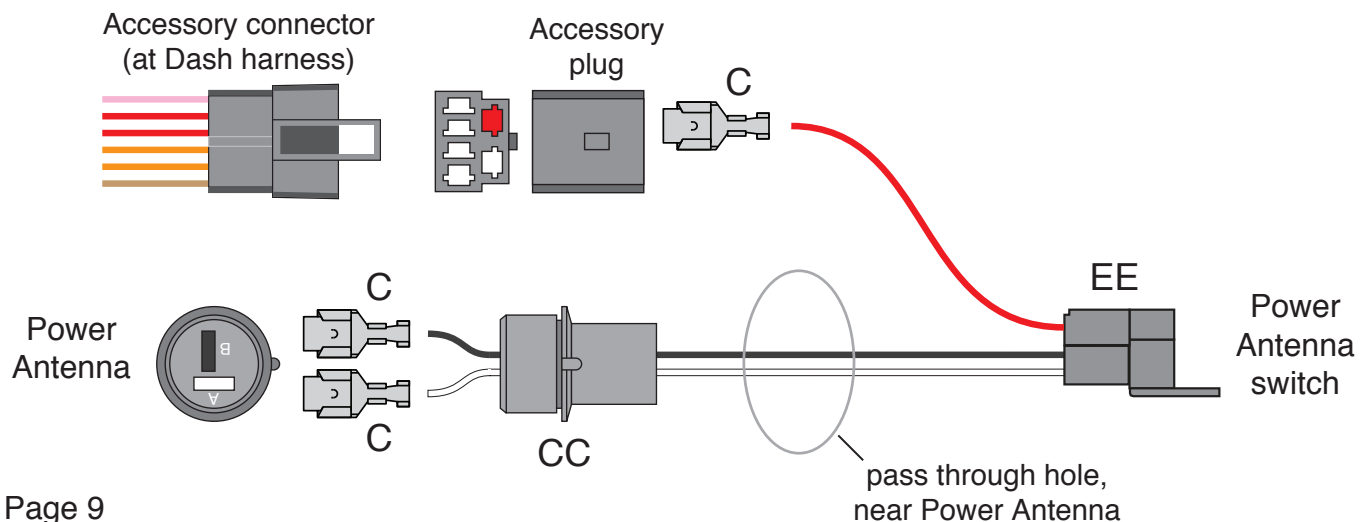

## Dash Light wiring:

gray wire from Dash harness

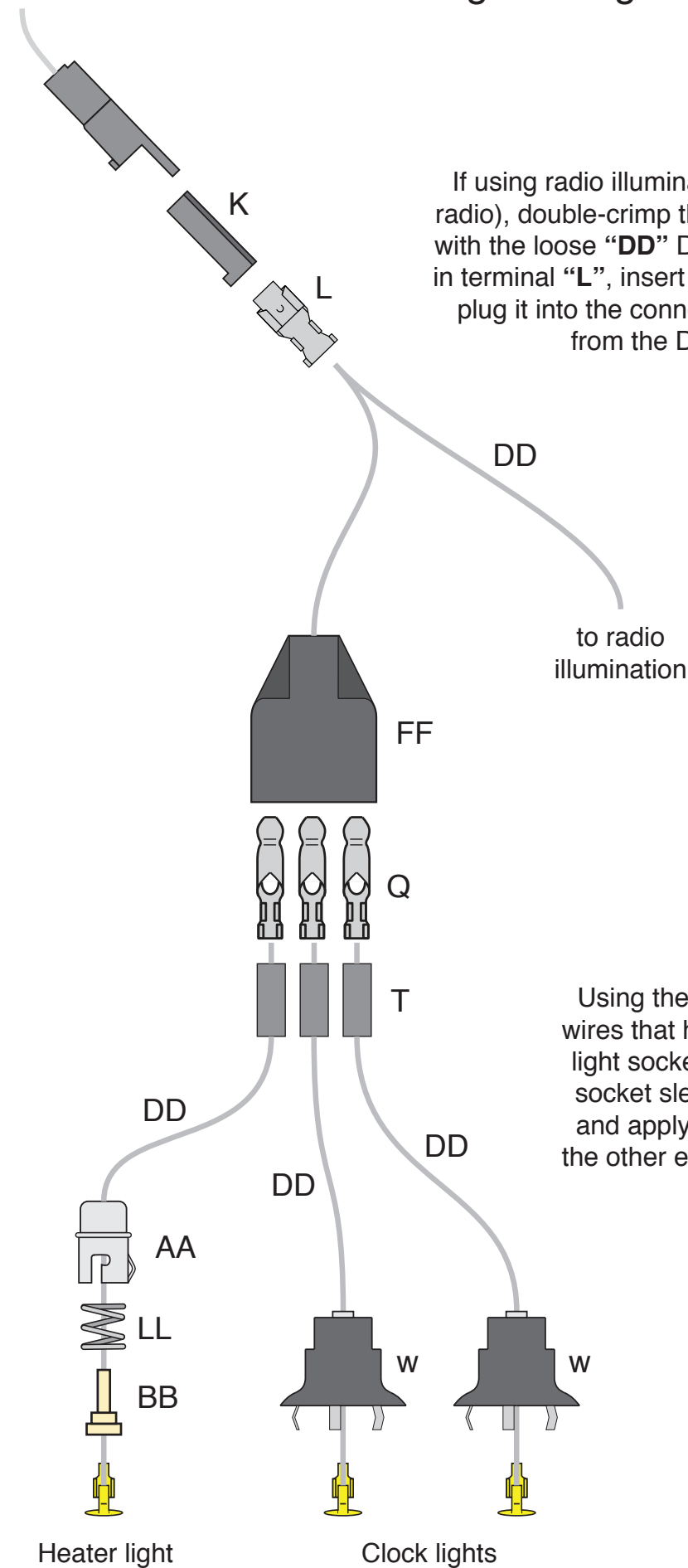

If using radio illumination (such as the stock radio), double-crimp the "FF" Candelabra wire with the loose "DD" Dash Light Extension wire in terminal "L", insert it into connector "K" and plug it into the connector with the gray wire from the Dash harness.

Using the three "DD" Dash Light Extension wires that have a terminal at one end, slide on light sockets "W" and "AA" (also "BB" light socket sleeve at socket "AA"), cut to length and apply "T" sleeves and terminals "Q" to the other end, then plug into "FF" Candelabra connector.











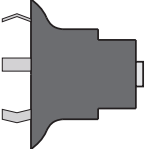



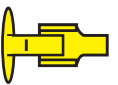
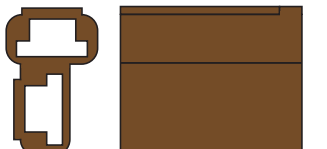

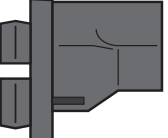
www.americanautowire.com 856-933-0801

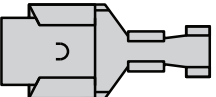
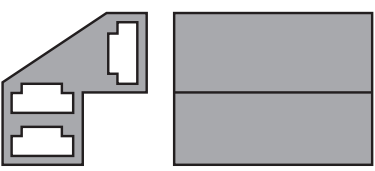
**1963-67 Corvette**  
 Classic Update Series  
**510612** 92971411 Rev 7.0 1/7/2019

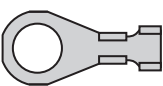
# Gauge Cluster harness installation instructions:

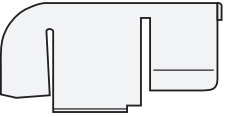
Shown below, are the supplied misc. terminals, plastic connector bodies, light sockets and hardware that will be used to complete your Gauge Cluster harness connections. They are itemized and referred to on this page, just as they are on the following pages of this Gauge Cluster instruction set.

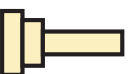
- |   |   |   |   |   |   |
|---|---|---|---|---|---|
| A |    | (light socket, 13 pcs.)                         | M |    | (spring, smaller metal light socket, 1 pc.)         |
| B |    | (spring, plastic light socket, 1 pc.)           | N |    | (56 series 2-way female conn, 2 pcs.)               |
| C |    | (terminal rivet, 20 pcs.)                       | P |    | (56 series 2-way female conn, 1 pc.)                |
| D |    | (terminal, plastic light socket ground, 2 pcs.) | R |  | (56 series 2-way female conn, 1 pc.)                |
| E |   | (plastic light socket, 1 pc.)                   | T |  | (56 series 1-way female conn, 3 pcs.)               |
| F |  | (56 series single female terminal, 8 pcs.)      | U |  | (56 series 3-way female conn, 1 pc.)                |
| G |  | (splice clip, 3 pcs.)                           | V |  | (small ring terminal for smaller gauge wire, 1 pc.) |
| H |  | (shrink tubing, 3 pcs.)                         |   |   |   |
| J |  | (reflector, smaller metal light socket, 1 pc.)  |   |   |   |
| K |  | (smaller metal light socket, 1 pc.)             |   |   |   |
| L |  | (insert, plastic light socket, 1 pc.)           |   |   |   |



www.americanautowire.com 856-933-0801

**1963-67 Corvette**

*Classic Update Series*

**510612**

92971411 Rev 7.0 1/7/2019

## How to install lamp sockets and lamp socket terminals.

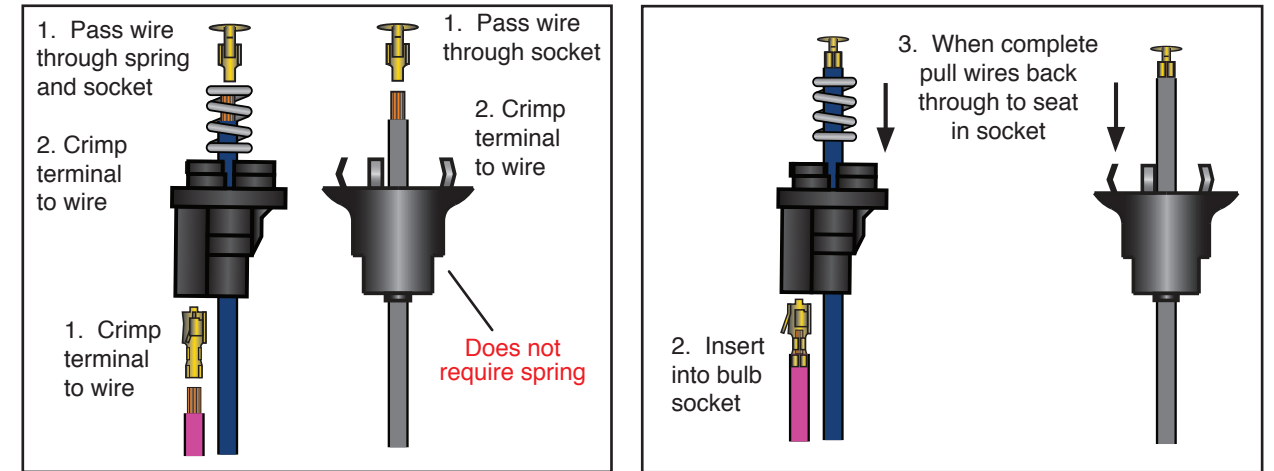

## How to use the splice clip to join multiple wires.

Below is just an **EXAMPLE** of how to use the splice clip and shrink tubing; see your specific application on the following pages for actual splice information.

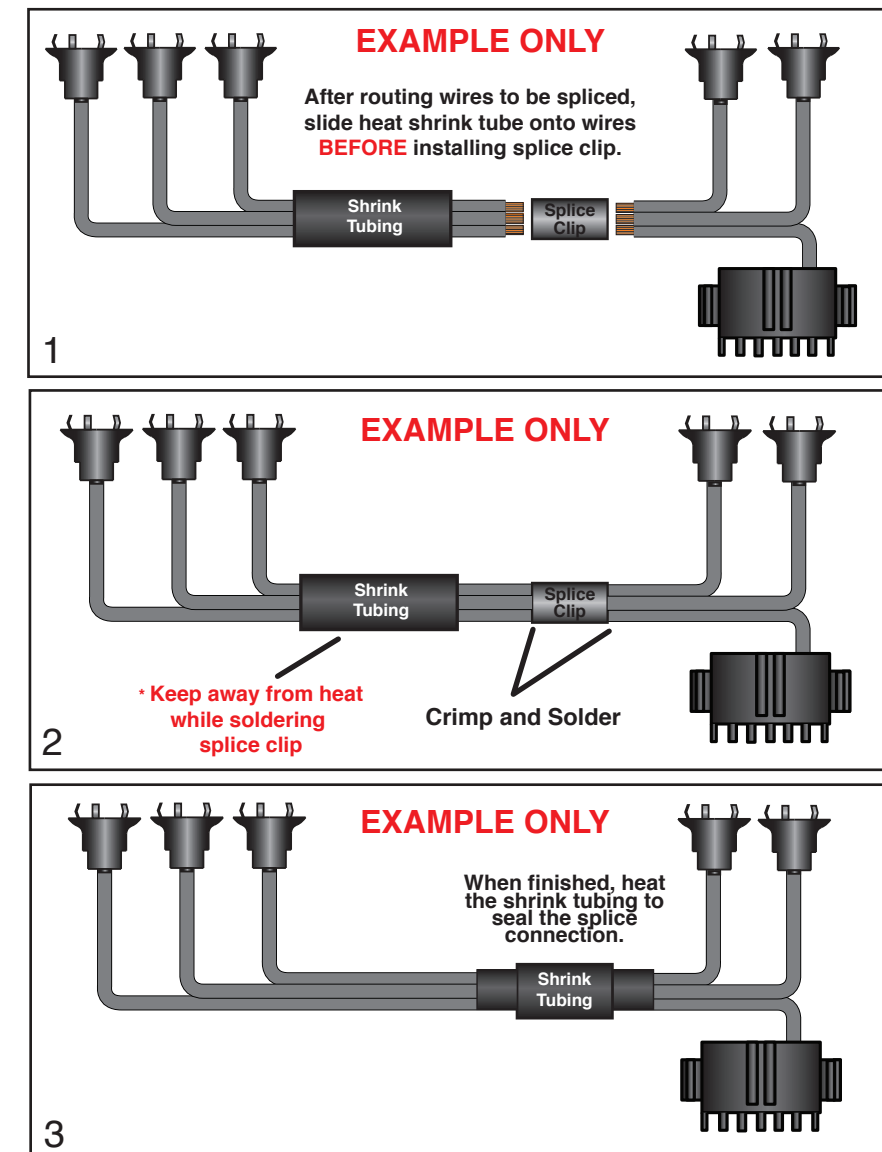



# Gauge Cluster harness installation instructions:

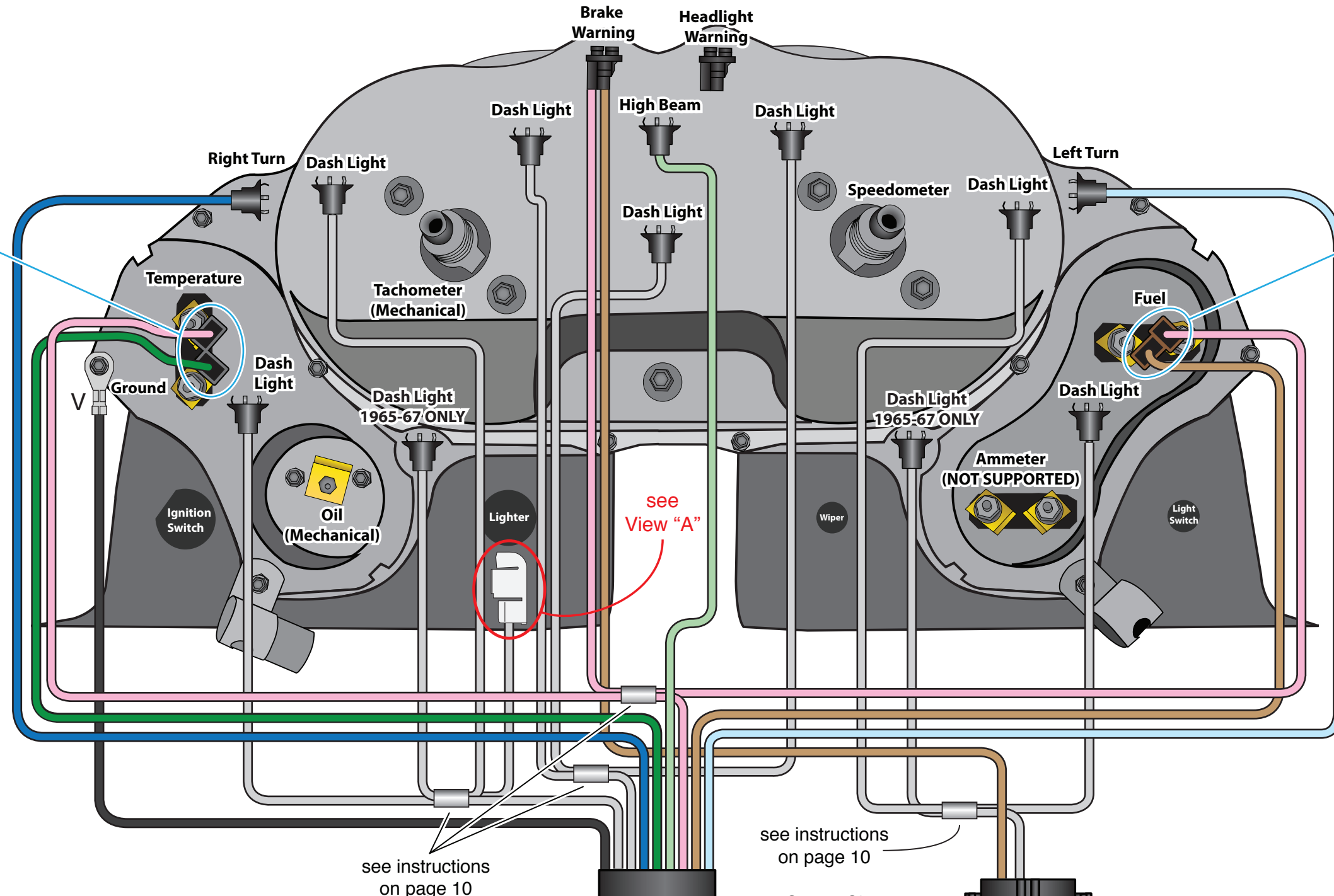
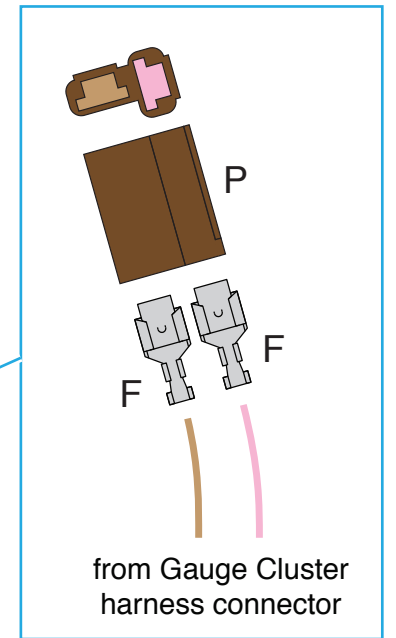
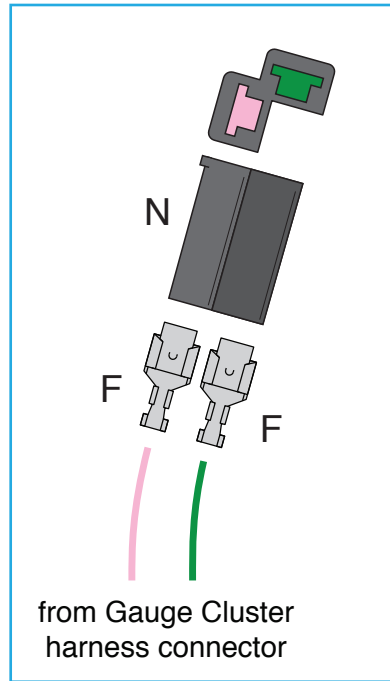

For proper wire locations, refer to "Detail View"

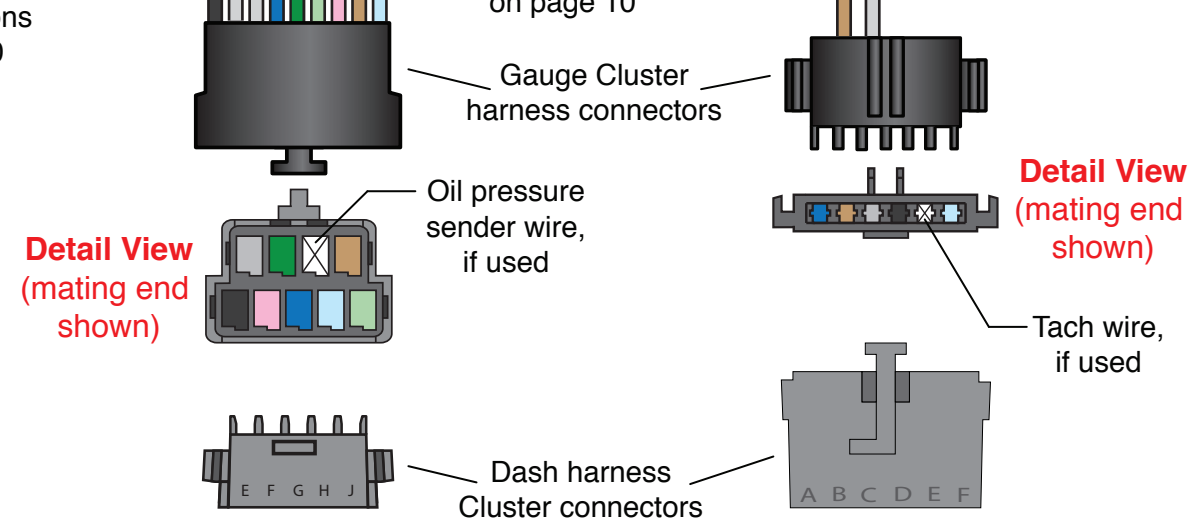
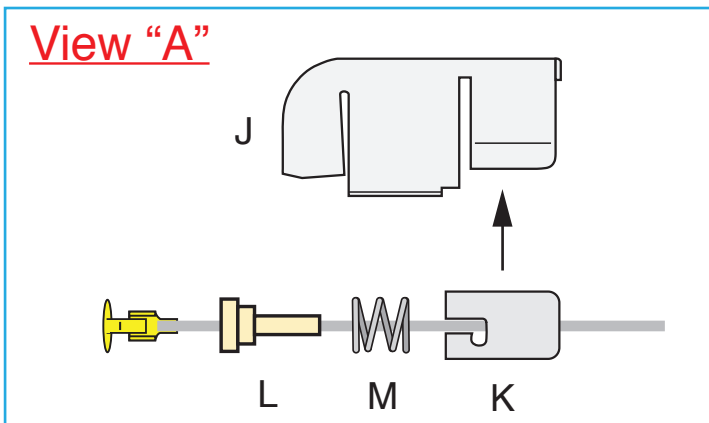

**1963-67 Corvette**  
*Classic Update Series*  
**510612** 92971411 Rev 7.0 1/7/2019

# Gauge Cluster harness (aftermarket gauges) installation instructions:

## TURN SIGNAL AND HI-BEAM LAMP CONNECTIONS

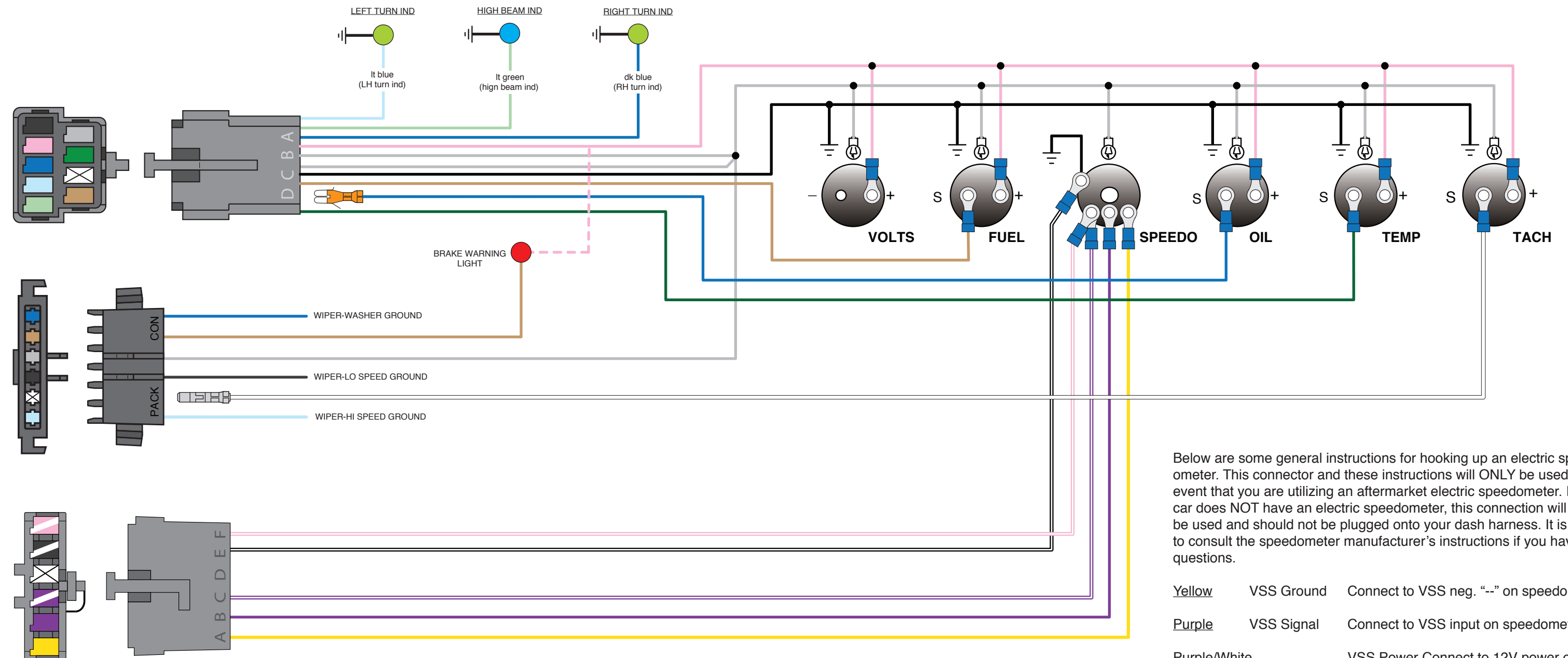

Below are some general instructions for hooking up an electric speedometer. This connector and these instructions will ONLY be used in the event that you are utilizing an aftermarket electric speedometer. If your car does NOT have an electric speedometer, this connection will NOT be used and should not be plugged onto your dash harness. It is best to consult the speedometer manufacturer's instructions if you have any questions.

- Yellow VSS Ground Connect to VSS neg. "--" on speedometer.
- Purple VSS Signal Connect to VSS input on speedometer.
- Purple/White speedometer. VSS Power Connect to 12V power on speedometer.
- Black/White Speedo Ground Connect to ground on speedometer.
- Pink/White Speedo Power Connect to 12v power on speedometer.  
NOTE: This wire will double onto the same stud as the purple/white VSS power wire from above.



See pages 12-14.

# Gauge Cluster harness installation instructions:

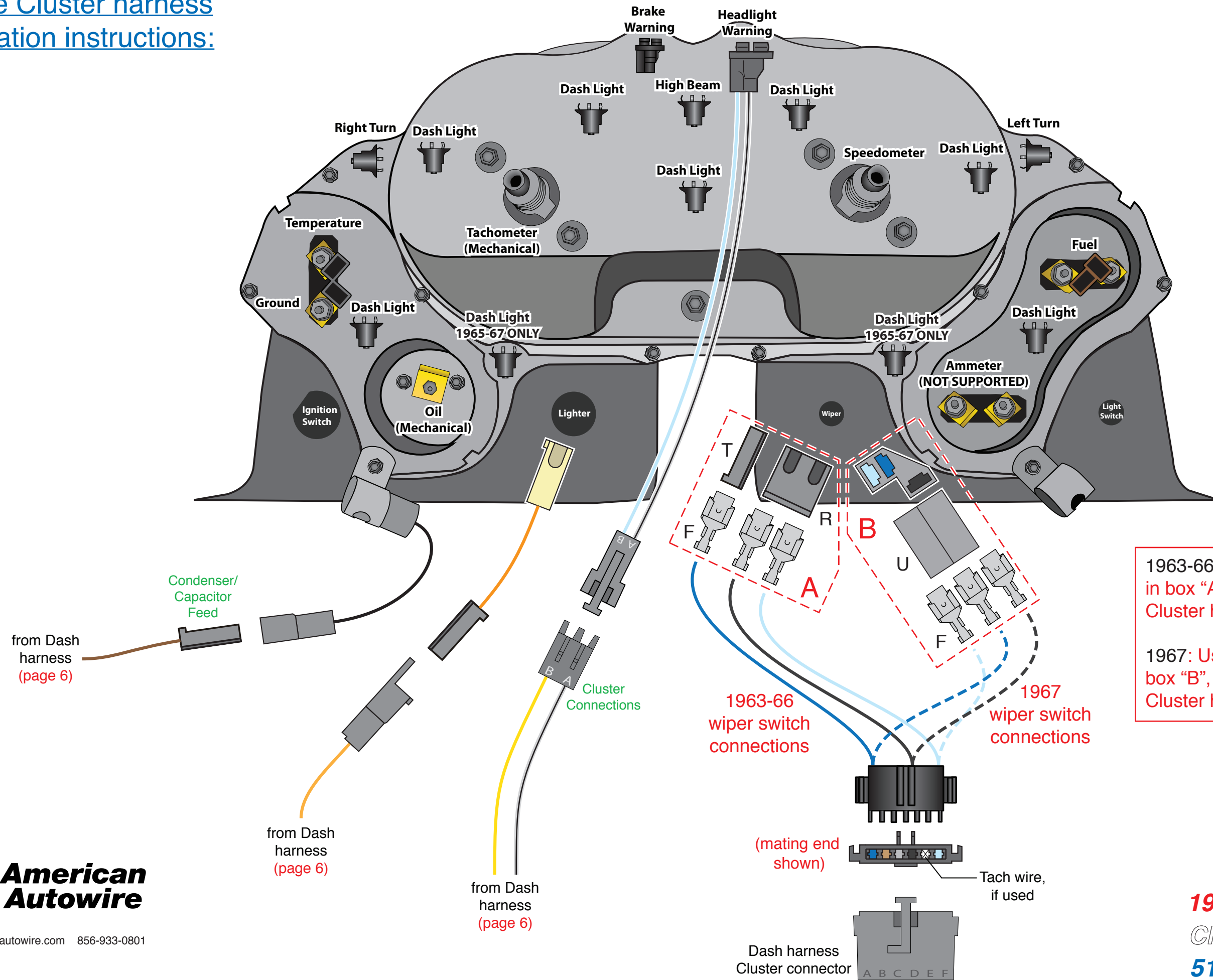

1963-66: Use terminals and connectors in box "A", to the left, to connect Gauge Cluster harness to the wiper switch.

1967: Use terminals and connectors in box "B", to the left, to connect Gauge Cluster harness to the wiper switch.



www.americanautowire.com 856-933-0801

**1963-67 Corvette**  
 Classic Update Series  
**510612** 92971411 Rev 7.0 1/7/2019

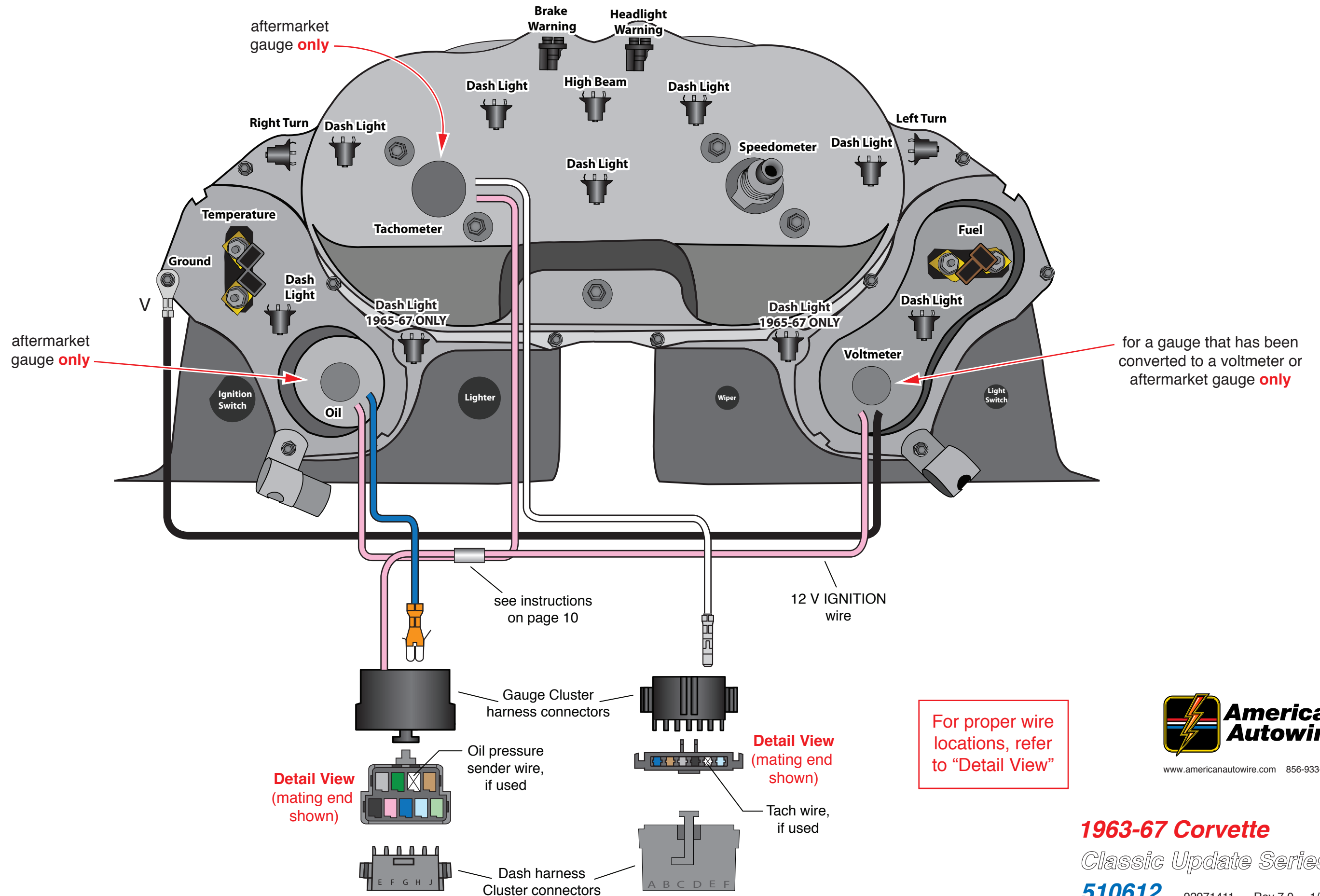

# Gauge Cluster harness (optional aftermarket functions) installation instructions:







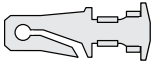
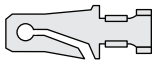
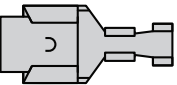
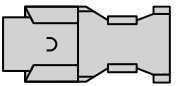
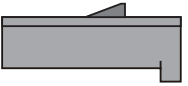
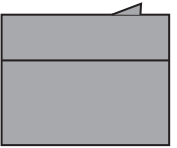
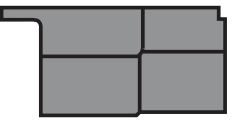
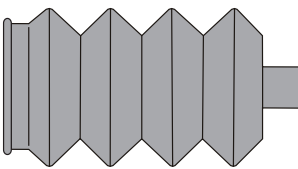

## Rear Body harness installation instructions:

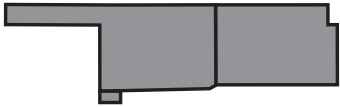
Shown below, are the supplied misc. terminals, plastic connector bodies, boots and wire extensions that will be used to complete your Rear Body harness connections. They are itemized and referred to on this page, just as they are on the following pages of this Rear Body instruction set.

- A  (56 series single male terminal, 6 pcs.)
- B  (56 series double male terminal, 3 pcs.)
- C  (56 series single female terminal, 10 pcs.)
- D  (56 series double female terminal, 5 pcs.)
- E  (56 series 1-way female conn, 3 pcs.)
- F  (56 series 2-way female conn, 2 pcs.)
- G  (56 series 2-way male conn, 2 pcs.)
- H  (boot, 6 pcs.)
- J  (bullet terminal, 4 pcs.)

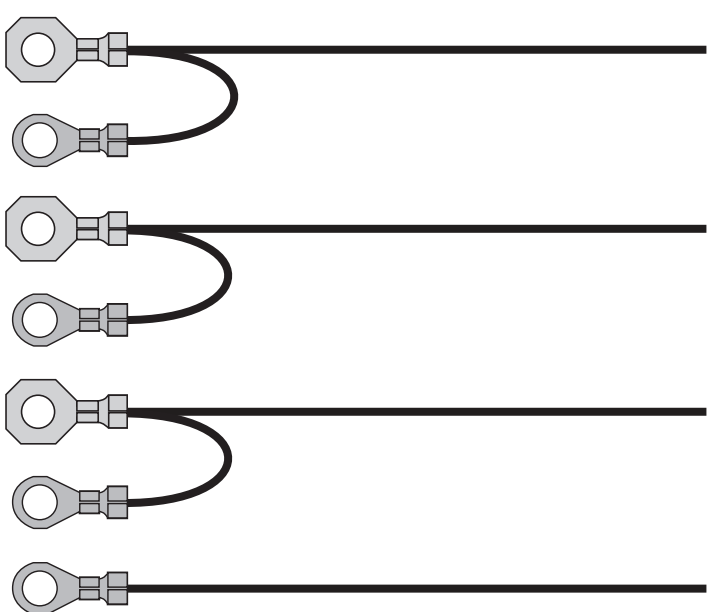
- K  (56 series 1-way male conn, 2 pcs.)
- L  (splice barrel, 1 pc.)
- M  (heat shrink, 1 pc.)
- N  (parking brake wire, **1967 only**, - reference, 1 pc.)
- P  (license plate light extension - reference, 1 pc.)
- R  (tail, license and back-up light, ground extensions - reference, 4 pcs.)



**1963-65 without  
back-up lights**

**Rear Body harness installation instructions:**

pass through  
hole (grommet  
not supplied)

Rear Body  
(at Dash harness,  
near rear kick panel)

to dome  
light

3rd brake  
light

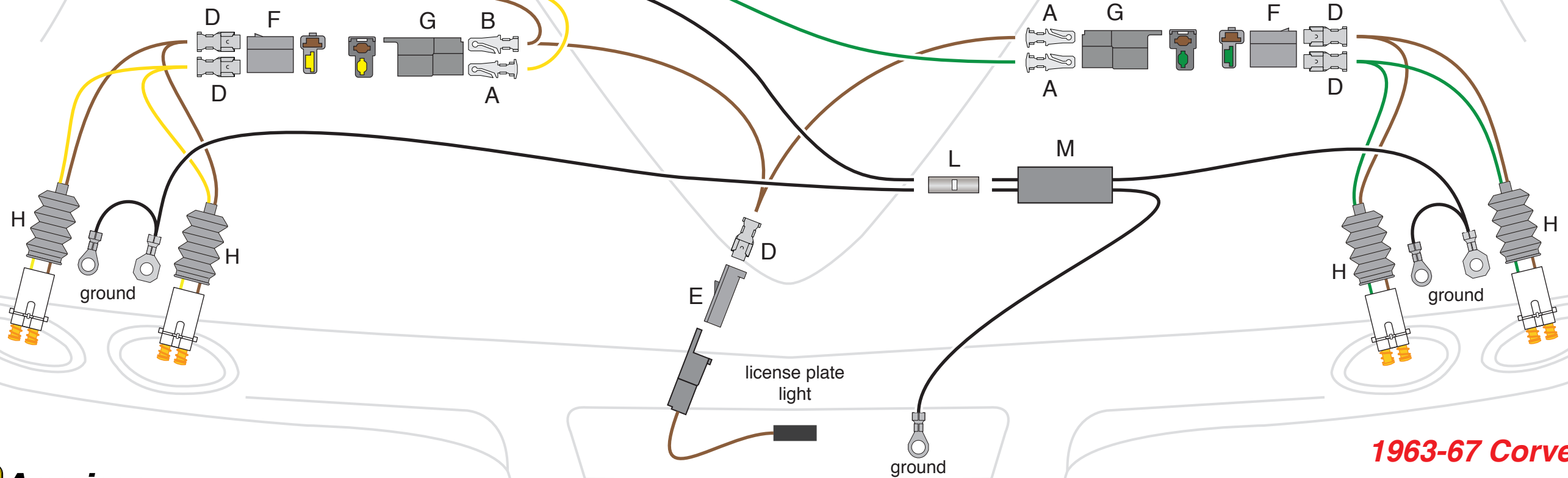

**1963-67 Corvette**  
*Classic Update Series*  
**510612** 92971411 Rev 7.0 1/7/2019



**1963-66 with  
back-up lights**

**Rear Body harness installation instructions:**

pass through  
hole (grommet  
not supplied)

Rear Body  
(at Dash harness,  
near rear kick panel)

to dome  
light

3rd brake  
light

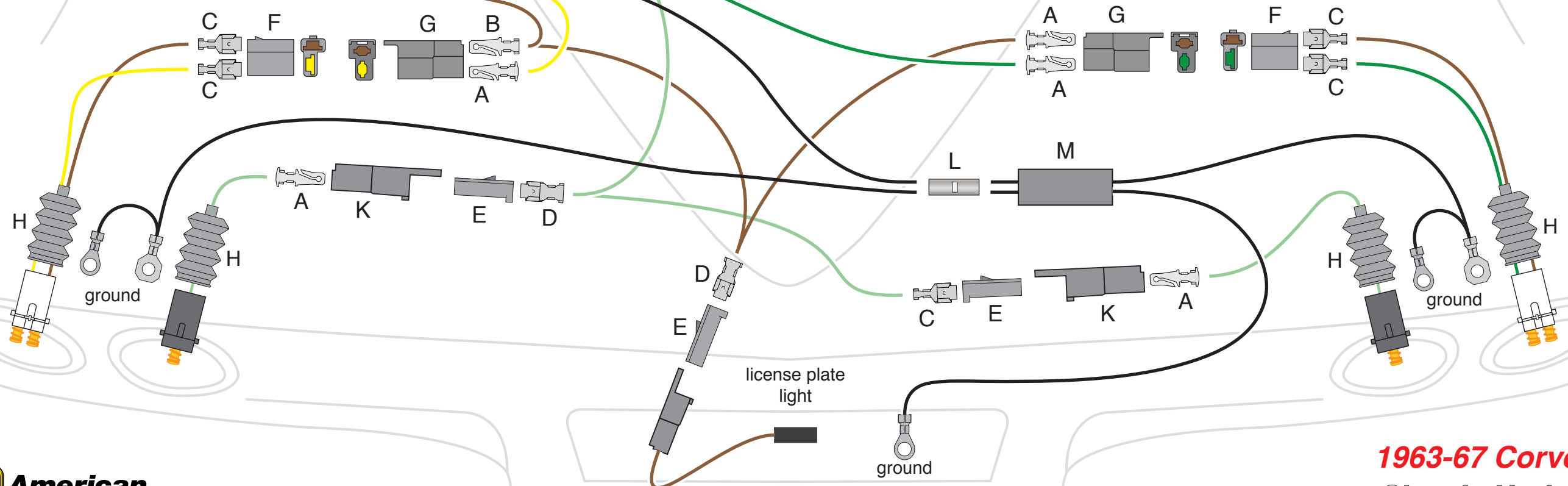

**1963-67 Corvette**  
*Classic Update Series*  
**510612** 92971411 Rev 7.0 1/7/2019



1967

# Rear Body harness installation instructions:

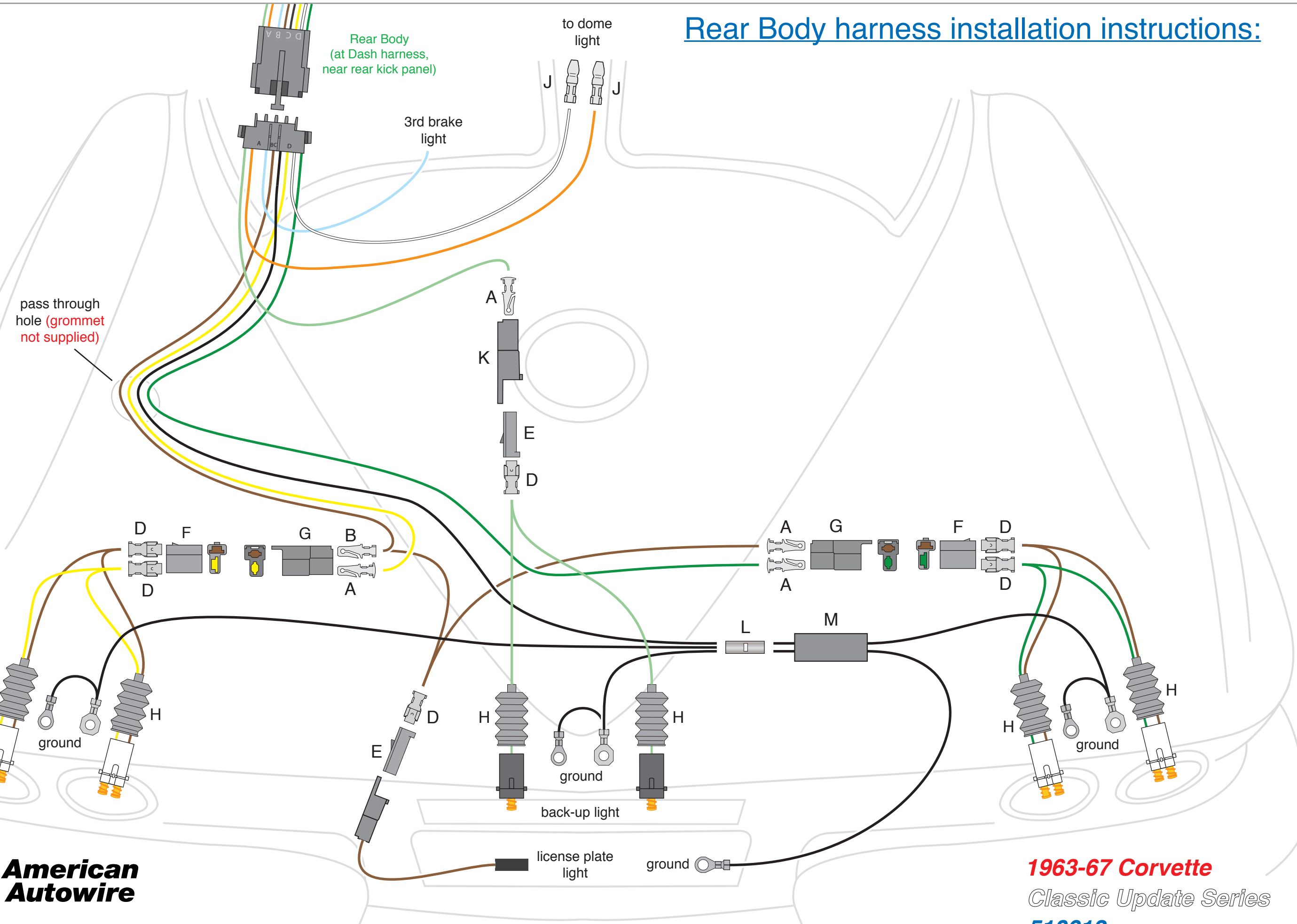



# Rear Body harness installation instructions:

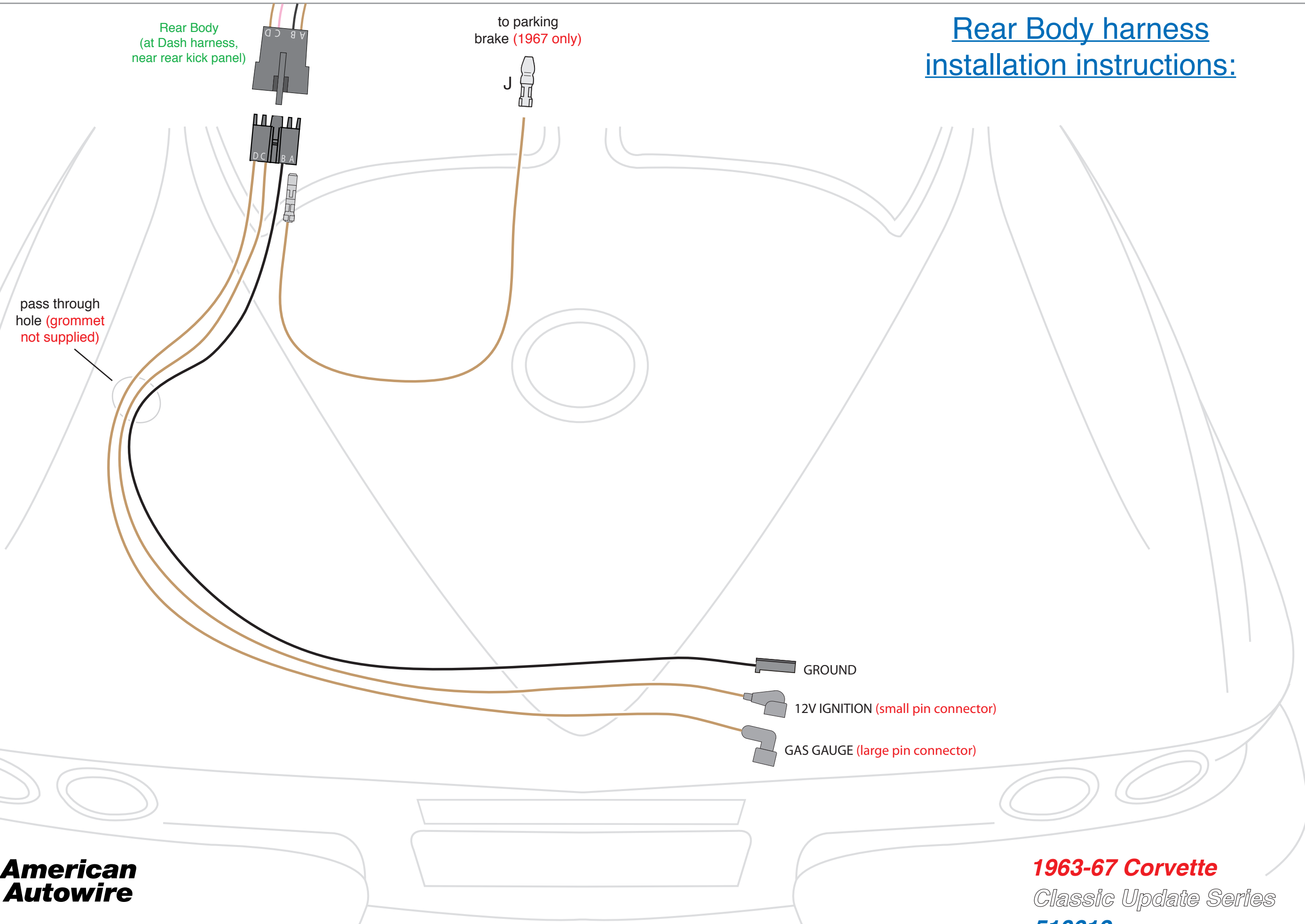

**1963-67 Corvette**  
Classic Update Series  
**510612** 92971411 Rev 7.0 1/7/2019

## Front Light harness installation instructions:

Shown below, are the supplied misc. terminals and plastic connector bodies, that will be used to complete your Front Light harness connections. They are itemized and referred to on this page, just as they are on the following pages of this Front Light instruction set.

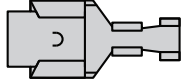
A  (56 series single female terminal, 10 pcs.)

B  (56 series double female terminal, 2 pcs.)

C  (56 series 3-way female conn, 2 pcs.)

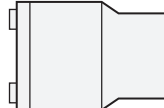
D  (terminal cover, 4 pcs.)

E  (female terminal, right angle, 5 pcs.)

F  (56 series 2-way female conn, 2 pcs.)

G  (56 series 3-way female conn, 2 pcs.)

H  (56 series single male terminal, 10 pcs.)

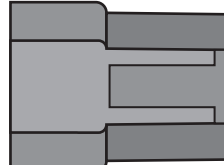
J  (56 series 3-way male conn, 2 pcs.)

K  (56 series single female connector, 2 pcs.)

# Front Light harness installation instructions:

## Headlight Extension harness 510620

**NOTE:** If you have a 1963 car with original fiberglass H/L buckets, all 22 inches of the loom will be used "as-is". If your 1963-67 car has metal H/L buckets, cut the loom down and use about 10 inches of it. The 1963 fiberglass buckets also utilized a grommet. That grommet **is not included** in this kit. The cars with the metal buckets did not use any type of grommet.

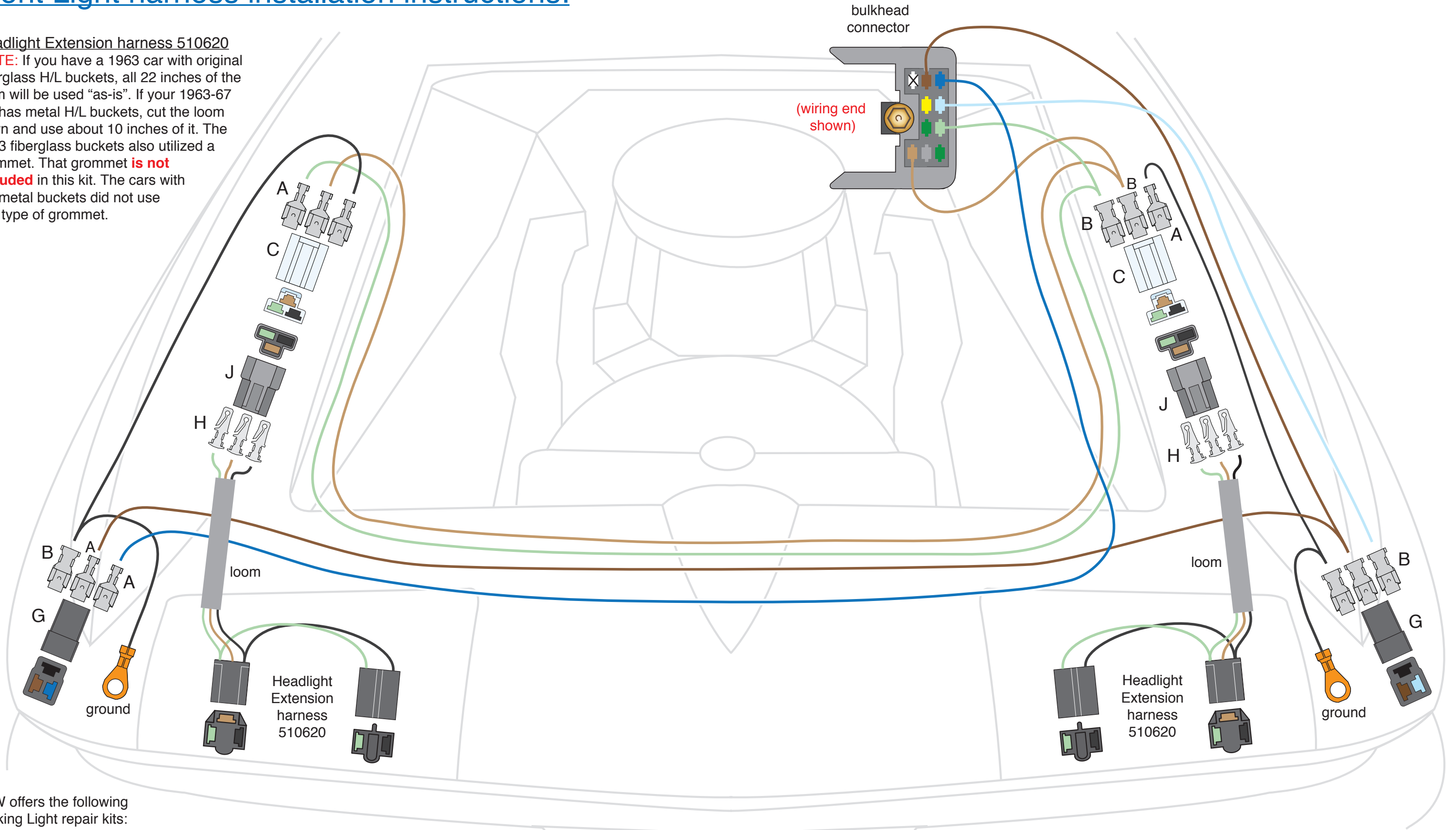

AAW offers the following  
Parking Light repair kits:

- 40059 (1963-66)
- 40060 (1967)



www.americanautowire.com 856-933-0801

**1963-67 Corvette**  
Classic Update Series  
**510612** 92971411 Rev 7.0 1/7/2019

# Front Light harness installation instructions:

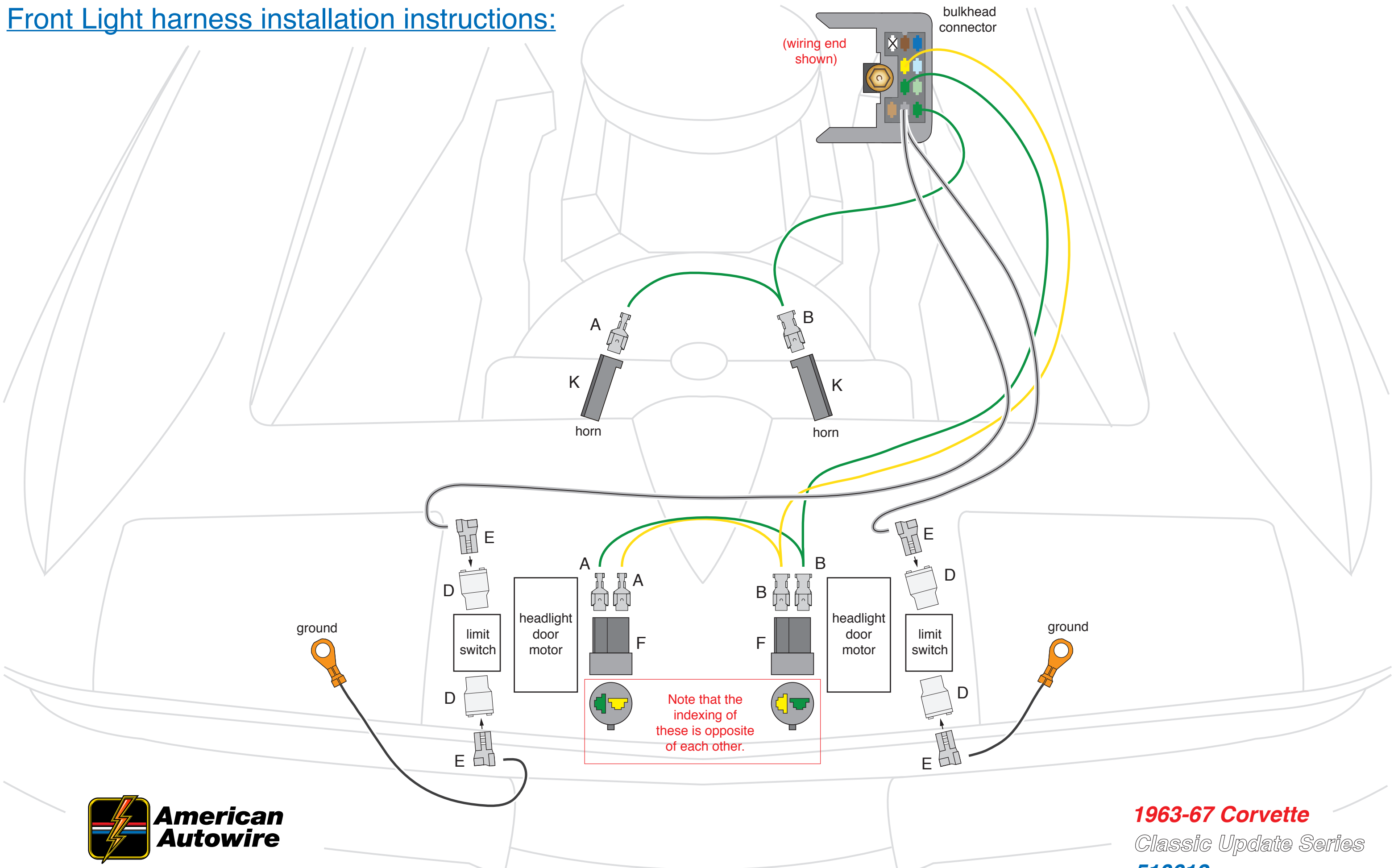









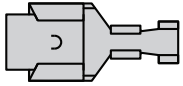
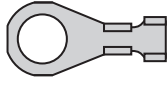
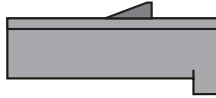

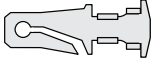
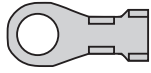

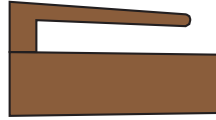

**1963-67 Corvette**  
Classic Update Series  
**510612** 92971411 Rev 7.0 1/7/2019

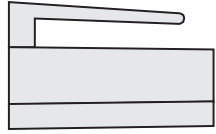

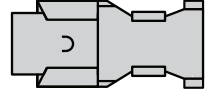
## Engine harness installation instructions:

Shown below, are the supplied misc. terminals, sleeves, plastic connector bodies and wires, that will be used to complete your Engine harness connections. They are itemized and referred to on this page, just as they are on the following pages of this Engine instruction set.

A		(56 series single female terminal, 8 pcs.)	L		(small ring terminal for smaller gauge wire, 4 pcs.)
B		(56 series single female connector, 2 pcs.)	M		(small rubber sleeve, 3 pcs.)
C		(56 series single female connector, 2 pcs.)	N		(56 series single male terminal, 3 pcs.)
E		(small ring terminal for larger gauge wire, 1 pc.)	P		(56 series 1-way male conn, 1 pc.)
F		(large rubber sleeve, 2 pcs.)	R		(56 series single female connector, 2 pcs.)
H		(56 series single female connector, 2 pcs.)	T		STARTER SOLENOID - R
J		(56 series single female connector, 2 pcs.)	U		ALTERNATOR IGN
K		(56 series double female terminal, 4 pcs.)	V		ELECTRIC FAN
			W		STARTER SOLENOID - S
			Y		Brake Switch



# Engine harness installation instructions:

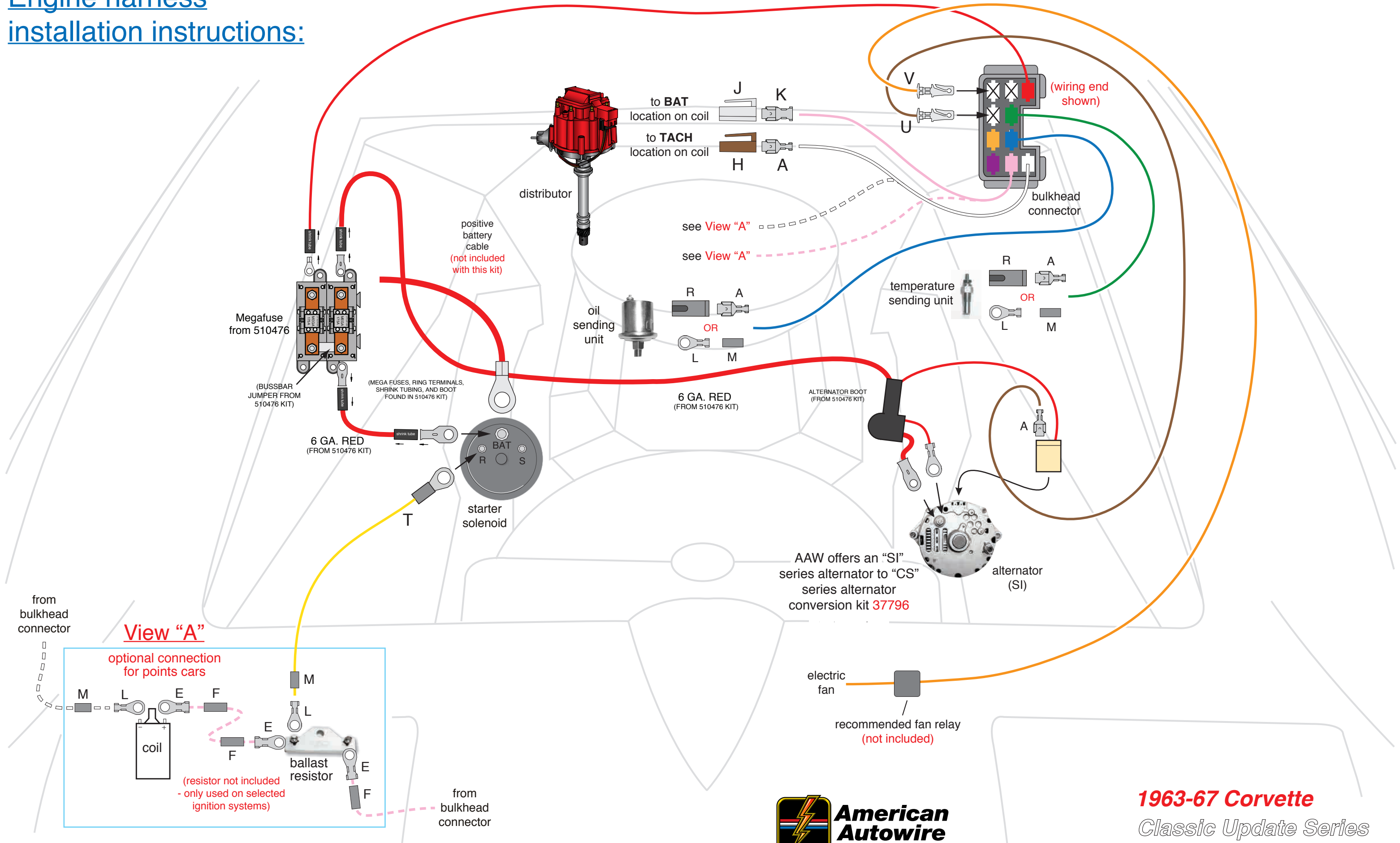

# Engine harness installation instructions:

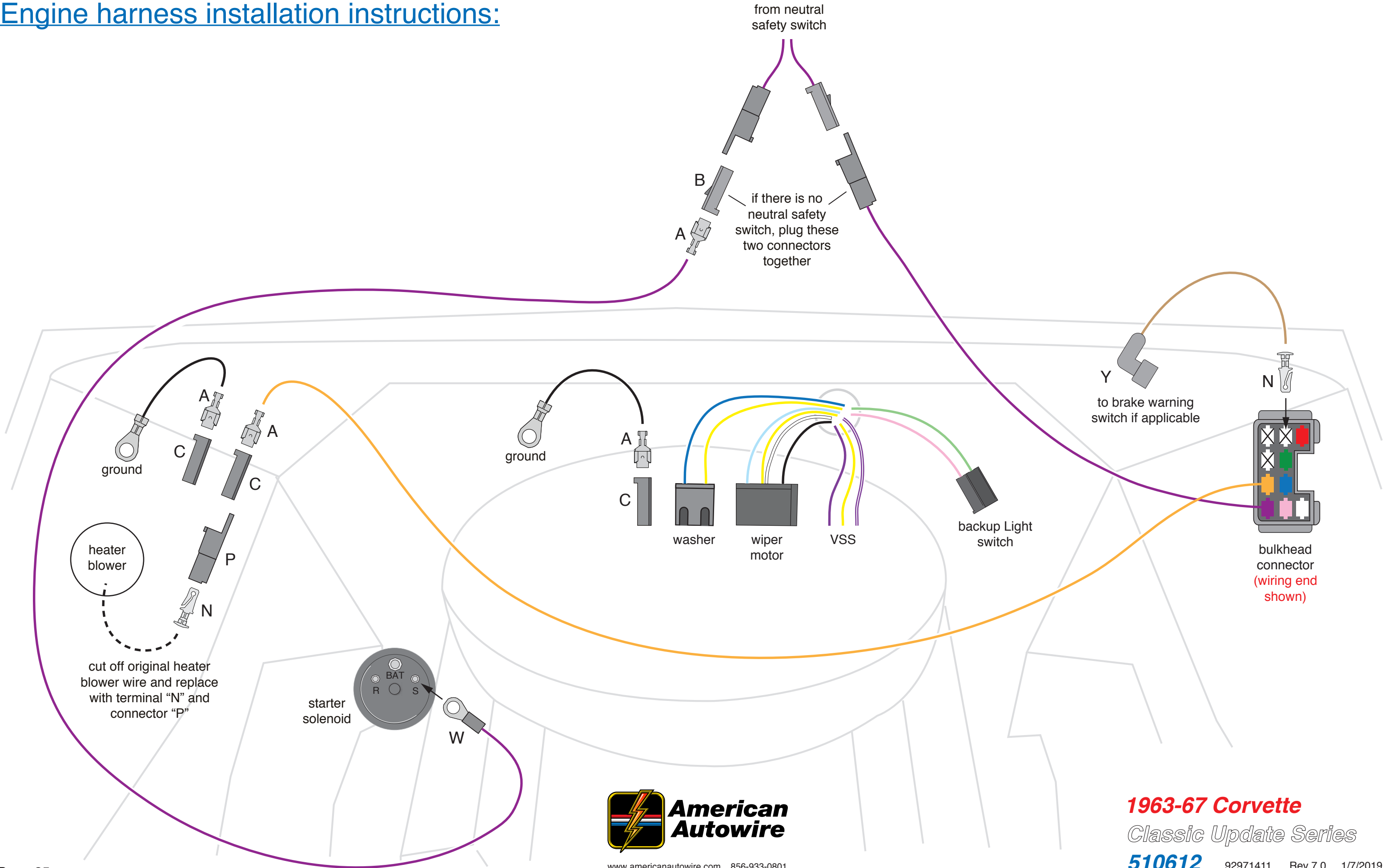

www.americanautowire.com 856-933-0801

**1963-67 Corvette**  
 Classic Update Series  
**510612** 92971411 Rev 7.0 1/7/2019

### **STEP 3: RECONNECT YOUR BATTERY:**

When you have completed the installation and are ready to reconnect the battery, make sure that the following electrical system grounds are in place:

- A. Battery is grounded to the ENGINE BLOCK.
- B. Battery is grounded to the frame.
- C. Engine block is grounded to the frame.
- D. Body is grounded to the frame.

### **STEP 4: CHECK ALL ELECTRICAL FUNCTIONS:**

Any non-functioning items should be checked for proper installation. Any problems with your wiring and electrical circuit functions, should be addressed to American Autowire Systems, Inc. as soon as possible, to avoid any warranty problems.

If you have any questions concerning this or any of our products, please feel free to call us at 1-856-933-0801.





A  (1)  
 (144.0" 6 Gauge charge wire)

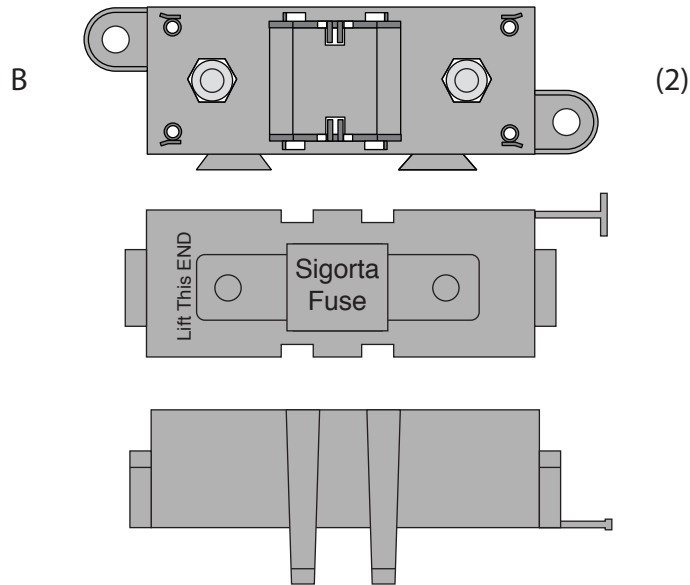

1. On this page, you will find the wire, fuse bodies, fuses, boot, ring terminals, and shrink tubing (items A through K) that are necessary to connect your alternator and main power feed for your new AAW wiring kit. Please be sure that all of the necessary components are present before starting this portion of your installation. If anything is missing, stop what you are doing and contact AAW at the number listed below right away.

2. On page 2, you will find directions for building the 2 Megafuse assemblies (items B,C and D) into one unit.

3. On page 3, you will find an overall concept of how to connect the Megafuse assemblies to your starter solenoid, alternator and main power feed of your new wiring system.

4. On page 4, you will find tips on building your charging circuit wires and assembling them and the main panel power feed wire to the Megafuse assemblies.

(Megafuse body, cover and two M8 x 1.25 nuts / lock washers)

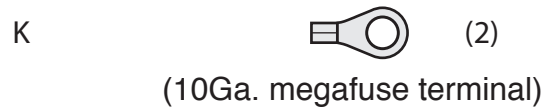
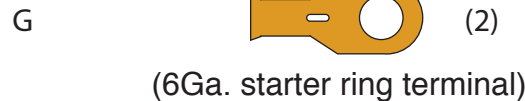
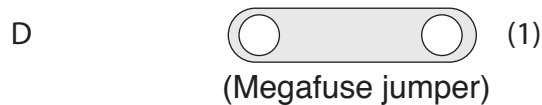
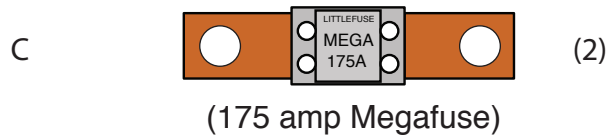

www.americanautowire.com 856-933-0801

PART #

510476

Z

DESCRIPTION:

Alternator and Main Power  
 Connection Kit  
 Various Applications

92972153 instruction sheet rev 0.1 6/24/2019

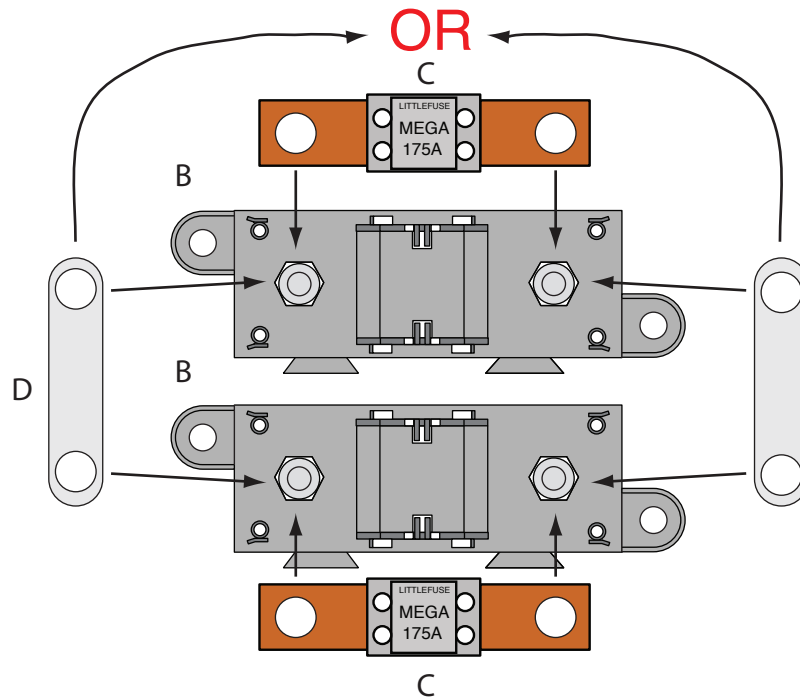

## Assembling the (2) Megafuse assemblies

**NOTE:** Find a suitable place, as close to the battery power source as possible, under the hood of your vehicle to mount the completed Megafuse assemblies. Keep in mind that you have 12 feet of 6Ga. charging wire, and that the main power feed coming from your panel or bulkhead connection must also be able to reach the assembly.

1. Take the two Megafuse bodies and covers (items B) and snap them together. Remove the 4 nuts and lock washers from the studs on the fuse body assemblies.
2. Install the Megafuse jumper (item D above) over two of the studs on the Megafuse bodies. It is very important that the jumper **MUST BE** assembled on the side that is going to connect to your main power connection (starter solenoid or battery feed).
3. Notch top cover to clear jumper D as shown at right.
4. Snap one 175amp fuse (items C) onto the studs of each of the two Megafuse bodies (items B), over the jumper, then loosely re-attach the 4 nuts and lock washers back onto the assembled Megafuses. The fuse assemblies are ready to install into your vehicle.

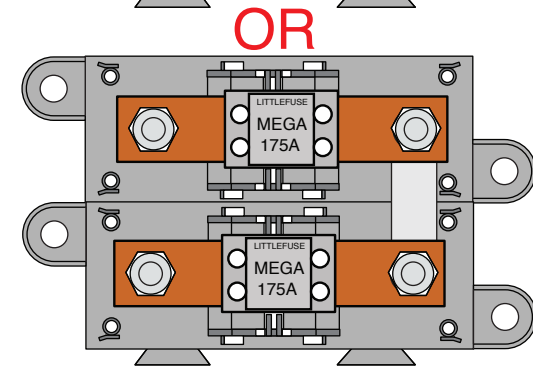
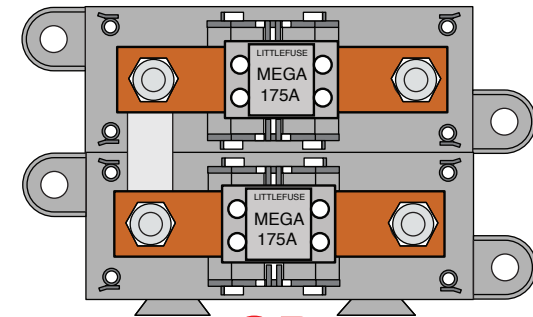

## Assembled Megafuses

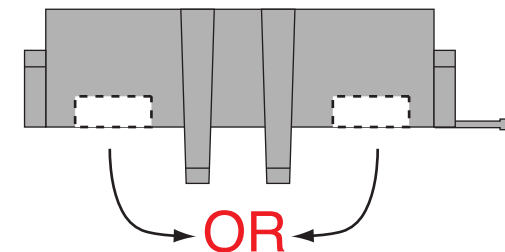

## Notched Cover

PART #

**510476**

**Z**

DESCRIPTION:

**Alternator and Main Power  
Connection Kit  
Various Applications**

92972153 instruction sheet rev 0.1 6/24/2019

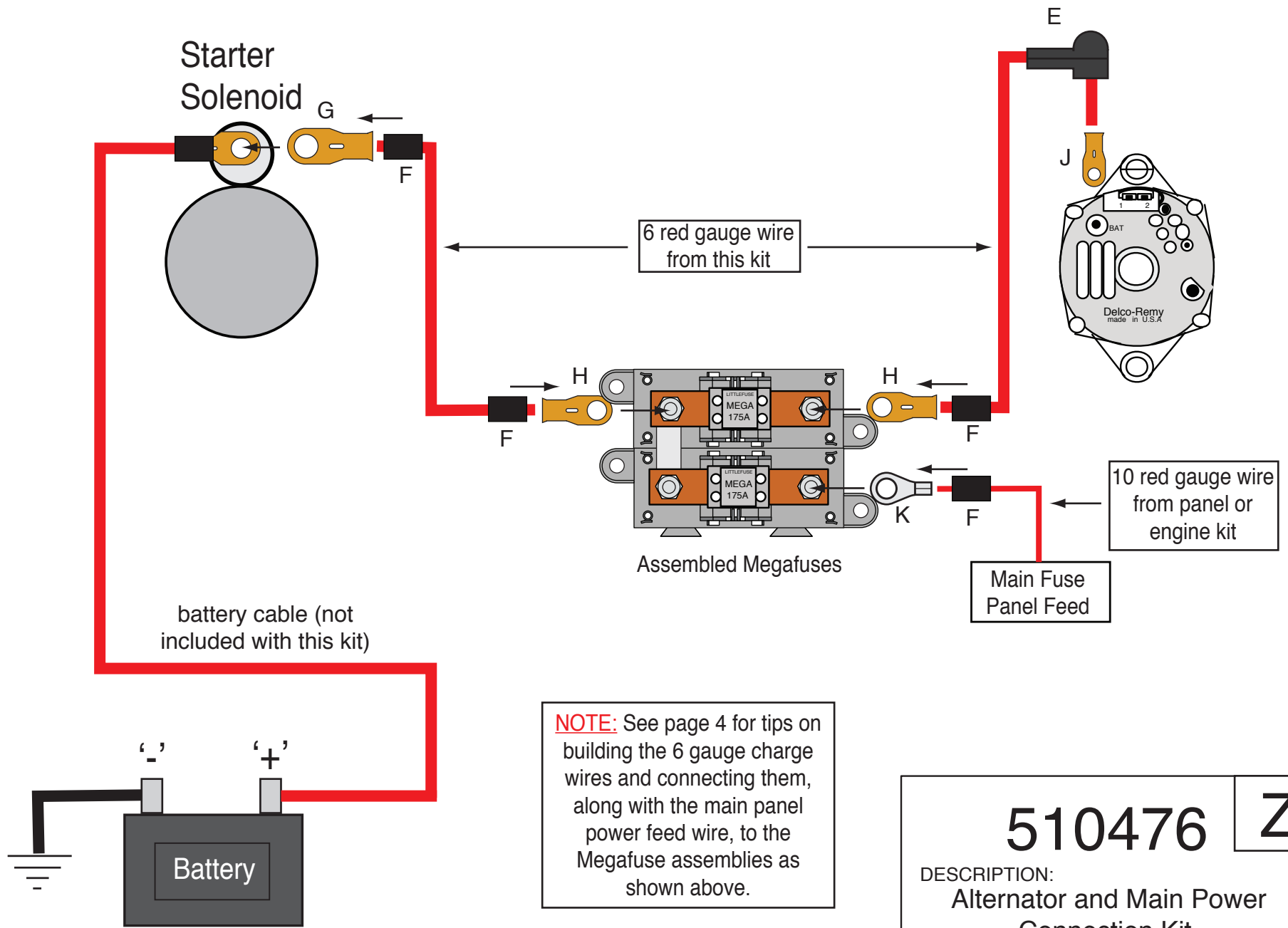

**NOTE:** See page 4 for tips on building the 6 gauge charge wires and connecting them, along with the main panel power feed wire, to the Megafuse assemblies as shown above.

<h1 style="margin: 0;">510476</h1>	Z
<p>DESCRIPTION:  <b>Alternator and Main Power Connection Kit</b>  <b>Various Applications</b></p>	
<p>92972153 instruction sheet rev 0.1 6/24/2019</p>	

## **Building the 6Ga. charge wires and connecting them and the main panel power feed wire to the Megafuse assemblies:**

**NOTE:** Make sure that your battery is disconnected! You will need to install the preassembled Megafuses from page 2 in your vehicle to start this part of the installation.

1. Pre-cut item F shrink tubing into (6) 1.00" - 1.25" pieces.
2. Take the 12-foot piece of 6Ga. red wire from this kit and route it from your starter (or other battery feed) over to the area where you have mounted your Megafuse and cut it to length. Strip the insulation on each end back 1/2". Install 2 pieces of shrink tubing F onto the wire. At the starter end, crimp and solder (1) of terminal G onto the wire. At the Megafuse end, crimp and solder (1) of terminal H onto the wire. Slide the shrink tubing over the terminals and heat it up to shrink it down.
3. Take the remaining portion of the 12-foot piece of 6Ga. red wire from this kit and route it from your alternator over to the area where you have mounted your Megafuse and cut it to length. Strip the insulation on each end back 1/2". Install 1 piece of shrink tubing F onto the wire. At the alternator end, slip on boot E as shown on page 3, then crimp and solder (1) of terminal J onto the wire. At the Megafuse end, crimp and solder (1) of terminal H onto the wire. Slide the shrink tubing over terminal H and heat it up to shrink it down.
4. Take the 10Ga. red main power feed wire from your engine or panel sub-kit and route it over to the area where you have mounted your Megafuse and cut it to length. Strip the insulation back 3/8". Install 1 piece of shrink tubing F onto the wire, then crimp and solder (1) of terminal K onto the wire.
5. Remove the 4 loosely tightened nuts and lock washers from the assembled Megafuses, then using the drawing on page 3 as a guide, install your pre-assembled wires from steps 2-4 above. Re-install the 4 nuts and lock washers onto the assembled Megafuses and tighten them down. This part of your installation is now complete.

**510476**

**Z**

DESCRIPTION:

**Alternator and Main Power  
Connection Kit  
Various Applications**

92972153 instruction sheet rev 0.1 6/24/2019



Most switches supplied with Classic Update and Universal Kits ship with the shaft pre-installed. In many instances, the switch can be installed without removing the shaft, but in some cases the switch shaft may need to be trimmed to fit your specific dash. In this situation, reference Trim to Fit instructions on the back of this page for details.

**To install your new headlight switch:**

1. Install the switch from behind the dash, and align the switch body with the mounting hole. The switch body has an alignment tab that must line up with the notch in the dashboard mounting hole.

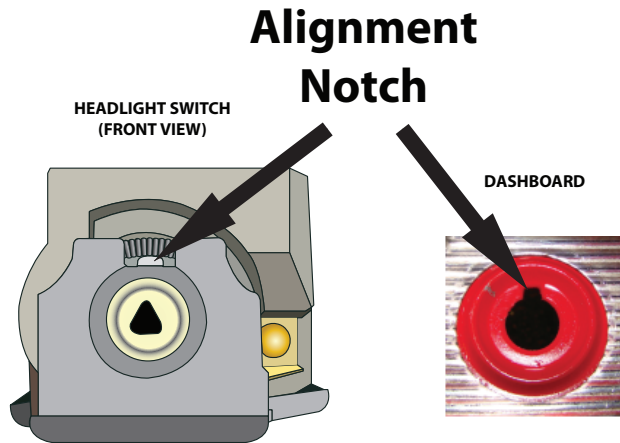

2. Install the switch mounting nut and tighten.
3. Gently press shaft into switch until it stops, then press firmly until it "clicks." Pull shaft back out to confirm it is seated correctly. The shaft should be locked into place inside switch.
4. If the shaft does not lock, reinsert applying moderate pressure and slowly move shaft side to side for lock to engage. Make sure switch body is still supported to prevent flexing. Press shaft firmly until it clicks into place.
5. Ensure the shaft is fully seated and in the off position.

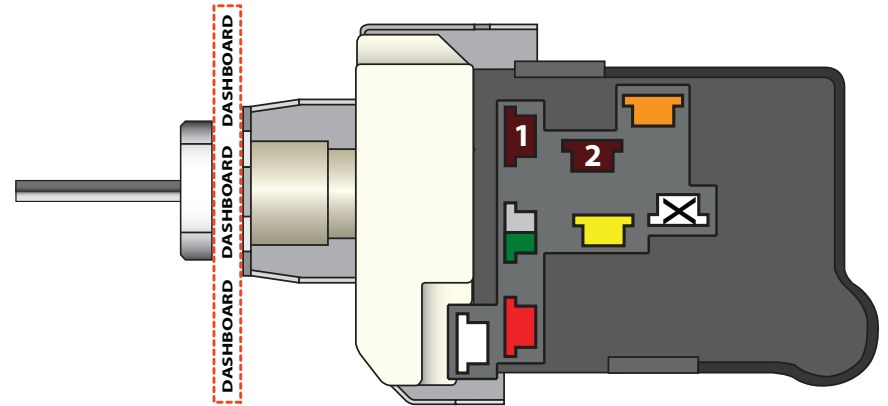

<b>1</b>	Parking Lights - Stay on with headlights
<b>2</b>	Tail Lights - On in the park and headlight positions
	Fused Battery Feed - For park, tail and dash lamps
	Headlight Feed - Power to the headlight dimmer switch
	12V Battery Feed - Unfused power to the switch for headlights
	Courtesy Ground - Ground feed to the dome and courtesy lights
	Part-time Parking Lights - Turns off when the headlights are on (Not supported by all kits)
	Dash Lights - Output to the dash light fuse or lights



www.americanautowire.com 856-933-0801

PART # **500332**

DESCRIPTION:  
**Headlight Switch**

92964649 Rev 3.0 1/10/2020

## To Trim Shaft to Fit or Remove Shaft:

The headlight shaft knob should extend from the face of the mounting nut, and must allow enough clearance for the switch to turn off. If the shaft is longer than necessary for your specific dash it can be trimmed to fit. Always trim the knob end of the shaft only and follow the guidelines below for best results.

1. With the headlight switch installed, loosen the set screw and remove the knob. Make sure the switch is in the "off" position by pushing the shaft toward the back of the switch.

**Switch in OFF position**  
(shaft pushed all the way in)

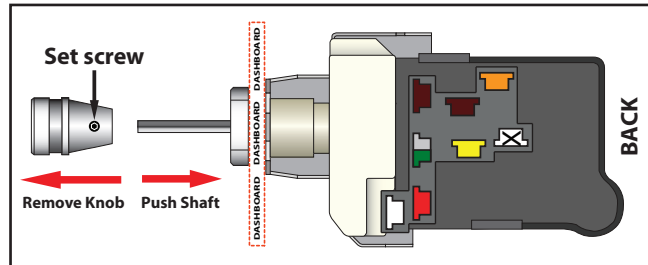

2. Set knob alongside shaft and mark the desired location for cutting on the shaft.

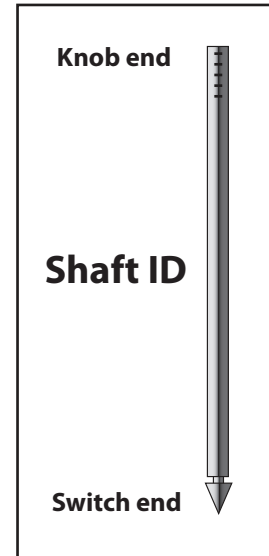
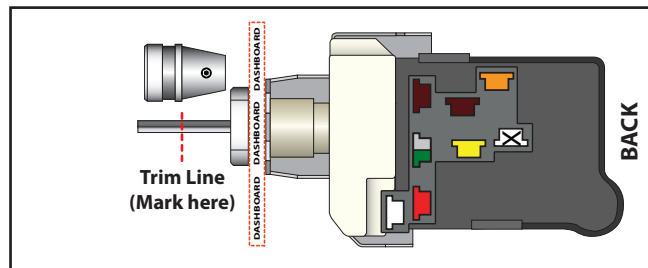

3. Remove the shaft and trim at mark. The shaft can be released from the switch by pulling it outward (toward the rear of the vehicle). Once fully in the "On" position, press and hold the release button on the base of the switch body. Once button is pressed, continue to pull the shaft outward. New switches may be tight, and it might be necessary to move the shaft side to side slightly while pulling to release.

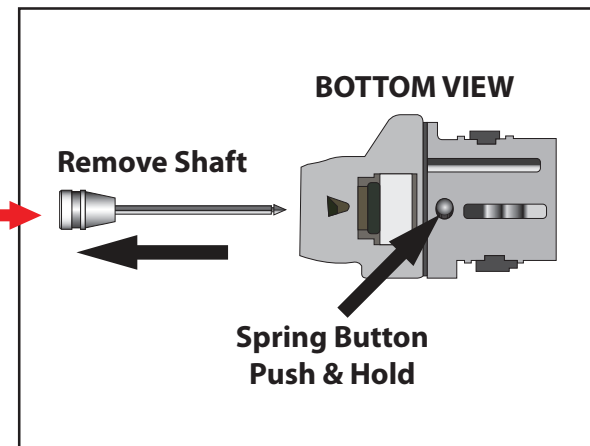
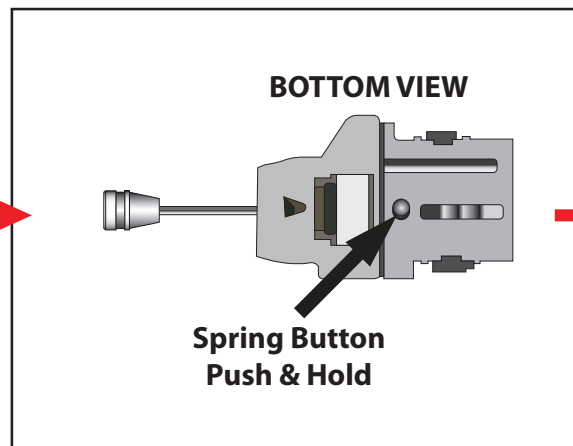
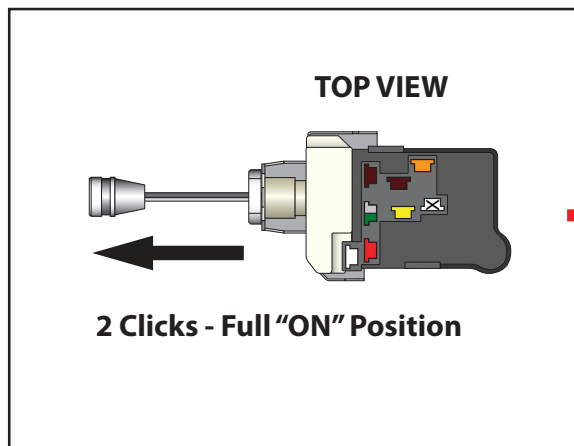

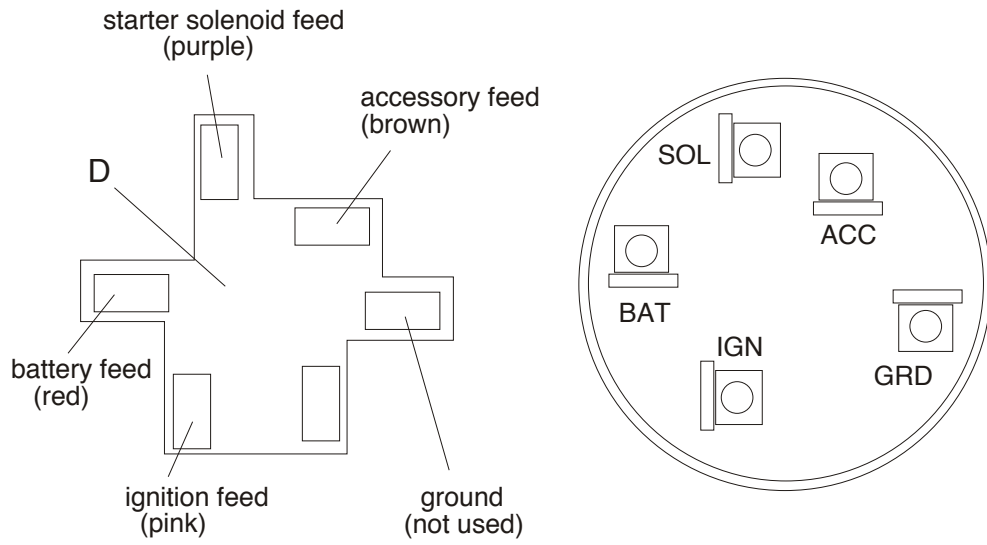

NOTE: View from back of connector.

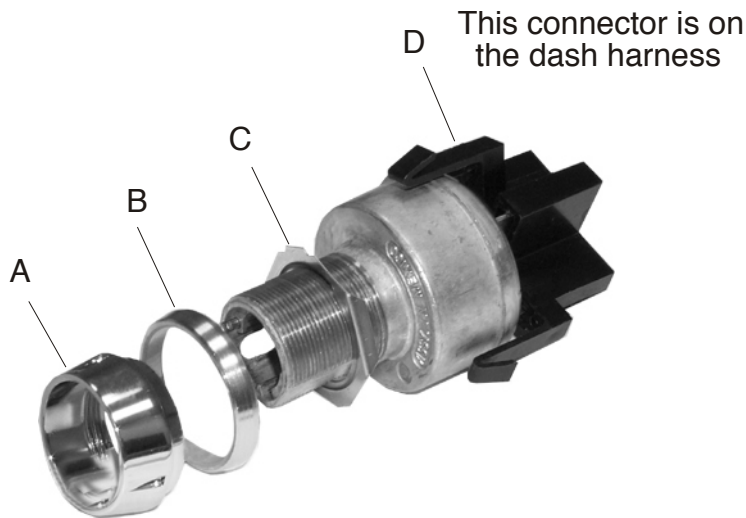

**NOTE:** Please keep in mind that this is an upgraded switch, not an original replacement, and as such, the flat side on this switch may be in a different location than was your original. If you mount this new AAW switch in your dash and the flat side is in fact in a different location, the key may not line up as the original did. This will not alter the performance of the switch in any way. If you wish for your key to line up as it did in the OEM application, you will need to file out the flat spot in your original dash opening so that the switch can be rotated to the correct position. Once the backing nut C is set so that the depth of the switch is correct for your application, and bezel nut A is firmly tightened, the switch will be secure and will not rotate.

#### INSTALLATION:

**NOTE:** The instruction sheet packaged with this switch shows a copper lamp holder bracket. That bracket is not used in this application and its installation can be ignored.

1. Due to the nature of the chrome plating on threaded collar A, AAW recommends threading the nut on and off of the switch by hand a few times to clean up the threads before installing the switch into your dash.
2. Plug in connector D from the dash wiring harness (bag G).
3. Install the back-up nut C onto the switch. The depth of this nut will have to be determined when mounting the switch.
4. Insert the switch into the hole in the dash panel.
5. Install your original dash bezel plate.
6. Slide on collar B.
7. Screw on threaded collar A
8. Insert your original or New AAW lock cylinder into the new switch to complete your installation.

**NOTE:** AAW has new lock cylinders with the correct GM style keys for your new 500684 ignition switch. Check below for your vehicle's correct application.



AAW P/N 500672 (with finger guard):

500423 - 1955-56 Chevy car  
 500434 - 1957 Chevy car  
 500481 - 1955-59 Chevy Truck  
 510217 - 1959-60 Chevy Impala  
 510063 - 1961-64 Chevy Impala  
 510267 - 1953-62 Chevy Corvette



AAW P/N 500674 (smooth face):

500467 - 1947-55 Chevy Truck  
 500560 - 1960-66 Chevy truck  
 510360 - 1965 Chevy Impala  
 510372 - 1966-68 Chevy Impala



www.americanautowire.com 856-933-0801

**IGNITION SWITCH**  
 Classic Update Series  
 VARIOUS APPLICATIONS

**500684**

92965941 instruction rev 6.0 8/1/2018